

Installation manual
(Translation of original language)

EN

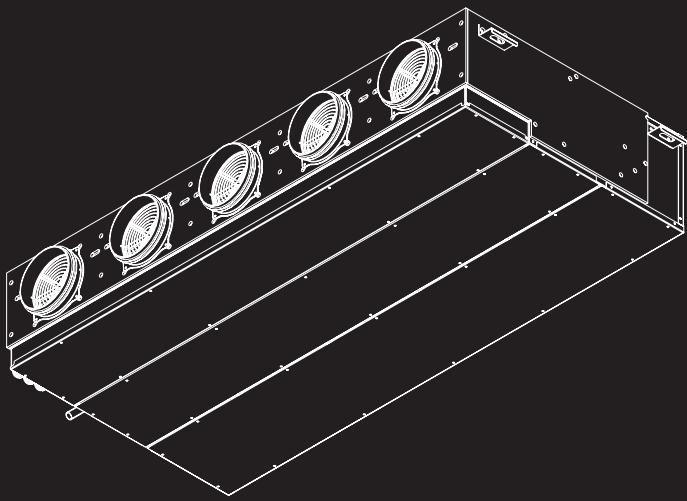

Panasonic[®]

N421341A Rev.02 05/2026

Multi-Zone Duct (MZD) DX

First of all, we would like to thank you for having chosen one of our units.

As you will realise, you have made a winning choice by purchasing a product that represents the state of the art in domestic air-conditioning technology.

Thanks to the product you have purchased and by following the suggestions in this manual, you will benefit from optimal environmental conditions with the lowest possible energy investment.

Compliance

This unit complies with European directives:

- Low voltage 2014/35 / EU
- Electromagnetic compatibility 2014/30 / EU

Markings



CONTENTS

Compliance	2	5.4 Connections	40
Markings	2	5.5 Functions	41
1. General information	4	6. Start-up	47
1.1 About the manual	4	6.1 Preliminary warnings	47
1.2 General warnings	5	6.2 First start-up	47
1.3 Basic safety rules	5	6.3 Plant delivery	48
1.4 Disposal	6	6.4 Switching off for extended periods	48
2. Information on refrigerant R32	7	7. Control configurations	49
2.1 Pictograms on the product	7	7.1 Automatic addressing procedure	49
2.2 General warnings	7	7.2 Automatic address setting via remote controller	49
2.3 Safety rules	7	7.3 How to check detailed setting 11	51
2.4 Electrical connections	7	7.4 How to adjust detailed settings using the remote controller	52
3. Product introduction	9	7.5 Test run using the remote controller	54
3.1 Identification	9	8. Maintenance	56
3.2 Destination of use	9	8.1 Routine maintenance	56
3.3 Description of the appliance	9	9. Decommissioning	60
3.4 List of external components	10	9.1 Safety warnings	60
3.5 List of internal components	10	10. Faults and remedies	61
3.6 Configurations	11	10.1 Preliminary warnings	61
3.7 Compatible accessories	16	10.2 Troubleshooting table	61
4. Installation	18	10.3 Alarms displayed on the control panel of the external unit	61
4.1 Preliminary warnings	18	10.4 M7 alarms	63
4.2 Reception	18	11. Technical information	64
4.3 Dimensions and weights with packaging	18	11.1 Technical data	64
4.4 Handling with packaging	19	11.2 Dimensions	68
4.5 Storage	19	11.3 Wiring diagram	70
4.6 Unpacking	19	11.4 Pressure/ventilation curves	71
4.7 Handling without packaging	20	12. General features	72
4.8 Installation site	20	12.1 Accessory pairing	72
4.9 Minimum installation distances	21	13. Technical characteristics of accessories	74
4.10 Positioning	23	13.1 Mounting	74
4.11 Refrigeration connections	25		
4.12 Condensate drain connection	29		
4.13 Aeraulic connections	30		
4.14 Electrical connections	33		
5. Wall mounted control EEB749	37		
5.1 Interface	37		
5.2 Installation	37		
5.3 Connection diagram	39		

1. GENERAL INFORMATION

1.1 About the manual

This manual was written to provide all the explanations for the correct management of the appliance.

- ⚠ This instruction manual is an integral part of the appliance and must therefore be kept in a safe place and must ALWAYS accompany the appliance even if it is passed on to another owner or user, or transferred to another plant. If it is damaged or lost, download a copy from the website.
- ⚠ Read this manual carefully before proceeding with any operation and follow the instructions in the individual chapters.
- ⚠ Specific warnings are given in each chapter of the document and should be read before starting operations.
- ⚠ The Manufacturer accepts no liability for damage to persons or property resulting from failure to observe the regulations contained in this booklet.
- ⚠ This document is confidential under the terms of the law and may not be reproduced or passed on to third parties without the express authorisation of the Manufacturer.

Editorial pictograms

The pictograms in the following chapter provide quick and unambiguous information necessary for the correct and safe use of the machine.

Related to safety

⚠ High risk warning (bold text)

- The operation described above presents a risk of serious physical injury, fatality, major damage to the appliance and/or to the environment if not carried out in compliance with safety regulations.

⚠ Low risk warning (plain text)

- The operation described above presents a risk of minor physical injury or minor damage to the appliance and/or to the environment if not carried out in compliance with safety regulations.

⊘ Prohibition (normal text)

- Marks actions that are prohibited.

ⓘ Important information (bold text)

- This indicates important information that must be taken into account during the operations.

In the texts

Purpose of the actions

- ▶ Actions required
Expected responses following an action

- Lists

In the figures

- 1 The numbers indicate the individual components.

A Capital letters indicate a combination of components and dimensions.

- ① The white numbers in black marks indicate a series of actions to be carried out in sequence.
- Ⓐ The black letter in white identifies an image when there are several images in the same figure.

Pictograms on the product

Symbols are used in some parts of the appliance:

Related to safety



Read the instruction manual

Read the instructions carefully before performing any operation on the appliance.



Instruction manual

Read the information available in the technical documentation of the appliance.



Attention electrical hazard

- Warns relevant personnel of the presence of electricity and the risk of electric shock.

Recipients

User

Non-expert person capable of operating the product in safe conditions for people, for the product itself and the environment, interpreting an elementary diagnostic of faults and abnormal operating conditions, carrying out simple adjustment, checking and maintenance operations.

Installer

Expert person qualified to position and connect (hydraulically, electrically, etc.) the unit to the plant; this person is responsible for handling and correct installation according to the instructions provided in this manual and the national standards currently in force.

Service

Expert and qualified person authorised directly by the Manufacturer to carry out all routine and supplementary maintenance operations, as well as every adjustment, check, repair and replacement of parts necessary during the life of the unit.

Organisation of the manual

The manual is divided into sections each dedicated to one or more target groups.

General information

It addresses all recipients.

It contains general information and important warnings that should be known before installing and using the appliance.

Product introduction

Addressed to all recipients, contains general information on the product.

Installation and Operation

It is addressed exclusively to the installer.

Contains specific warnings and all information necessary for positioning, mounting, connecting the device and operation.

Commissioning, maintenance and troubleshooting

They are addressed exclusively to the Authorised Service Centre.

It contains specific warnings and useful information for the most common commissioning and routine maintenance.

Technical information

It addresses all recipients.

It contains detailed technical information about the appliance.

1.2 General warnings

- ⚠ Specific warnings are given in each chapter of the document and should be read before starting operations.
- ⚠ All personnel involved must be aware of the operations and dangers that may arise when beginning all unit installation operations.
- ⚠ Installation performed outside the warnings provided in this manual and use of the appliance outside the prescribed temperature limits will invalidate the warranty.
- ⚠ Any contractual or extra-contractual liability for damage caused to persons, animals or property, due to installation, adjustment and maintenance errors or improper use is excluded. All uses not expressly indicated in this manual are not permitted.
- ⚠ The installation of the appliances must be carried out by a qualified company which, on completion of the work, will issue a declaration of compliance to the person in charge of the plant in accordance with the regulations in force and the instructions provided in the instruction booklet accompanying the appliance.
- ⚠ First start-up and repair or maintenance operations must be carried out by the Authorised Service Centre or by qualified personnel following the provisions of this manual.
- ⚠ Do not modify or tamper with the appliance as this can lead to dangerous situations.
- ⚠ Use suitable personal protective clothing and equipment during installation and/or maintenance operations.

tions. The Manufacturer is not liable for the non-observance of the current safety and accident prevention regulations.

- ⚠ In case of liquid or oil leaks, isolate the main power supply of the system and close any water valves. Promptly contact the Authorised Service Centre or professionally qualified personnel, and refrain from personally intervening on the equipment.
- ⚠ When replacing components, use only original spare parts.
- ⚠ The Manufacturer reserves the right to make changes to its models at any time to improve its product, without prejudice to the essential characteristics described in this manual. The Manufacturer is not obliged to add such modifications to machines previously manufactured, already delivered, or under construction.
- ⚠ The appliance can be used by children aged 8 years and above and by persons with reduced physical, sensory, or mental capabilities, or those lacking experience or necessary knowledge, provided they are under supervision or have been given instructions concerning the safe use of the appliance and understand the hazards involved. Children should not play with the appliance. Cleaning and maintenance intended to be carried out by the user should not be done by children without supervision.

1.3 Basic safety rules

We would like to remind you that the use of products that use electricity and water involves observing certain basic safety precautions such as:

- ⊖ It is forbidden to touch the appliance with wet or damp body parts.
- ⊖ It is forbidden to carry out any operation before disconnecting the appliance from the power supply by setting the plant master switch to "OFF".
- ⊖ It is forbidden to modify the safety or adjustment devices without the authorisation and instructions of the appliance manufacturer.
- ⊖ It is forbidden to pull, unplug or twist the electrical cables coming out of the appliance, even if it is disconnected from the mains supply.
- ⊖ It is forbidden to introduce objects and substances through the openings provided for the intake and delivery of air.
- ⊖ It is forbidden to open the access doors to the internal parts of the appliance without first setting the plant master switch to "OFF".
- ⊖ It is forbidden to dispose of packaging material and leave it within reach of children as it can be a potential hazard.

1.4 Disposal



The symbol on the product or packaging indicates that the product should not be treated as normal household waste. Instead, it should be taken to an appropriate collection point for recycling of electrical, electronic, and battery equipment.

Proper disposal of this product avoids harm to humans and the environment and promotes the reuse of valuable raw materials.

For more detailed information about the recycling of this product, contact your local authority, your household waste disposal service, or the shop where you purchased the product.

Illegal disposal of the product by the user involves the application of the administrative sanctions provided for by the regulations in force.

This provision is only valid in the EU Member States.

⚠ Avoid disassembling the appliance yourself.

⚠ **Contact an Authorised Service Centre to disassemble the appliance.**

2. INFORMATION ON REFRIGERANT R32

- ⚠ The appliance must be installed in well-ventilated environments that have a minimum floor area as indicated in the table "Minimum Floor Area" based on the total refrigerant charge of the circuit.
- ⚠ **The refrigerant charge refers to the total amount of refrigerant in the circuit, which includes the factory charge and any additional charge.**
- ⚠ Please refer to the technical rating plate on the associated outdoor unit for the quantity of refrigerant loaded into the unit.
- ⚠ If the appliance is placed in a poorly ventilated area, precautions must be taken to prevent the accumulation of leaked refrigerant, thus avoiding the risk of fire or explosion.
- ⚠ The appliance should be placed in a room where there are no continuously operating open flames (such as a gas appliance in operation) or ignition sources (such as an operating electric heater).
- ⚠ Any ventilation openings must be kept clear of obstacles.
- ⚠ Perform the following checks:
 - Perform safety checks to ensure that the risk of combustion is minimised
 - avoid working in confined spaces
 - delimit the area around the workspace
 - ensure safe working conditions around the area by checking for flammable materials

2.1 Pictograms on the product

Symbols are used in some parts of the appliance:



Warning flammable material

- The refrigerant gas R32 is mildly flammable and odourless. Avoid proximity to continuous ignition sources such as open flames, gas appliances, electric heaters, lit cigarettes, etc.



Instructions

- Read the instructions carefully before performing any operation on the appliance.



Instructions for Service

- The Authorised Service Centre must read the instructions before performing any operation on the appliance.



Instructions for the User

- Further information is available in the technical documentation of the appliance.

2.2 General warnings

The document only contains some of the safety rules regarding R32 refrigerant. For more comprehensive information, please read the safety data sheet available from the retailer.

- ⚠ In each chapter, specific warnings are included for the operations described within. These warnings should be read before starting any activities.
- ⚠ All precautions regarding the handling of refrigerant must be followed in accordance with current regulations.

- ⚠ The unit uses R32 refrigerant, with a Global Warming Potential (GWP) of 675. Do not release R32 gas into the atmosphere.
- ⚠ The R32 refrigerant gas is mildly flammable and odourless.
- ⚠ Do not place flammable objects (spray cans) within 1 meter of the air discharge.
- ⚠ Avoid proximity to continuously operating ignition sources (open flames, gas appliances, electric stoves, lit cigarettes, etc.).

2.3 Safety rules

The document only contains some of the safety rules regarding R32 refrigerant. For more comprehensive information, please read the safety data sheet available from the retailer.

- 🚫 Smoking is prohibited near the appliance.

- 🚫 The use of mobile phones is prohibited near the appliance.
- 🚫 The use of leak detectors with halogen lamps is prohibited.

2.4 Electrical connections

- ⚠ The R32 refrigerant gas is mildly flammable and odourless.

- ⚠ All precautions regarding the handling of refrigerant must be followed in accordance with current regulations.

- ⚠ Avoid proximity to continuously operating ignition sources (open flames, gas appliances, electric stoves, lit cigarettes, etc.).
- ⊖ Smoking is prohibited near the appliance.
- ⊖ The use of mobile phones is prohibited near the appliance.
- ⚠ Perform the following checks:
 - Perform safety checks to ensure that the risk of combustion is minimised
 - avoid working in confined spaces
 - delimit the area around the workspace
 - ensure safe working conditions around the area by checking for flammable materials

3. PRODUCT INTRODUCTION

3.1 Identification

The appliance can be identified by the rating plate:

1. Technical rating plate

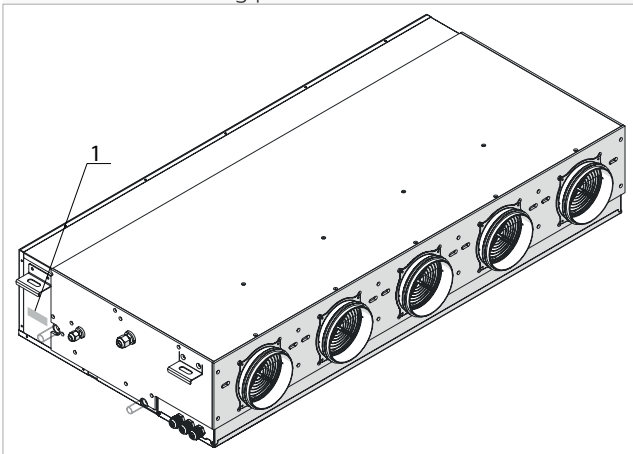

Technical rating plate

This shows the technical and performance specifications of the appliance.

⚠ Tampering with, removing or missing identification plates does not allow the product to be reliably identified by its serial number and therefore invalidates the warranty.

3.2 Destination of use

Designed for ceiling installation and horizontal wall installation, this compact unit is optimal for air conditioning systems.

3.3 Description of the appliance

Structure: high-strength, self-supporting frame in galvanized sheet metal with internal thermal and acoustic insulation.

Fans: low energy consumption centrifugal DC with forward-curved blades for reduced noise.

Filters: flat with Coarse filtration class.

Exchange coil: coil optimised for the best heat exchange

Models: 2 Panasonic sizes with different air flows are available.

3.4 List of external components

- 1. Electrical panel
- 2. Condensate drain for horizontal installation
- 3. Gas pipe
- 4. Liquid pipe
- 5. Condensate drain for vertical installation

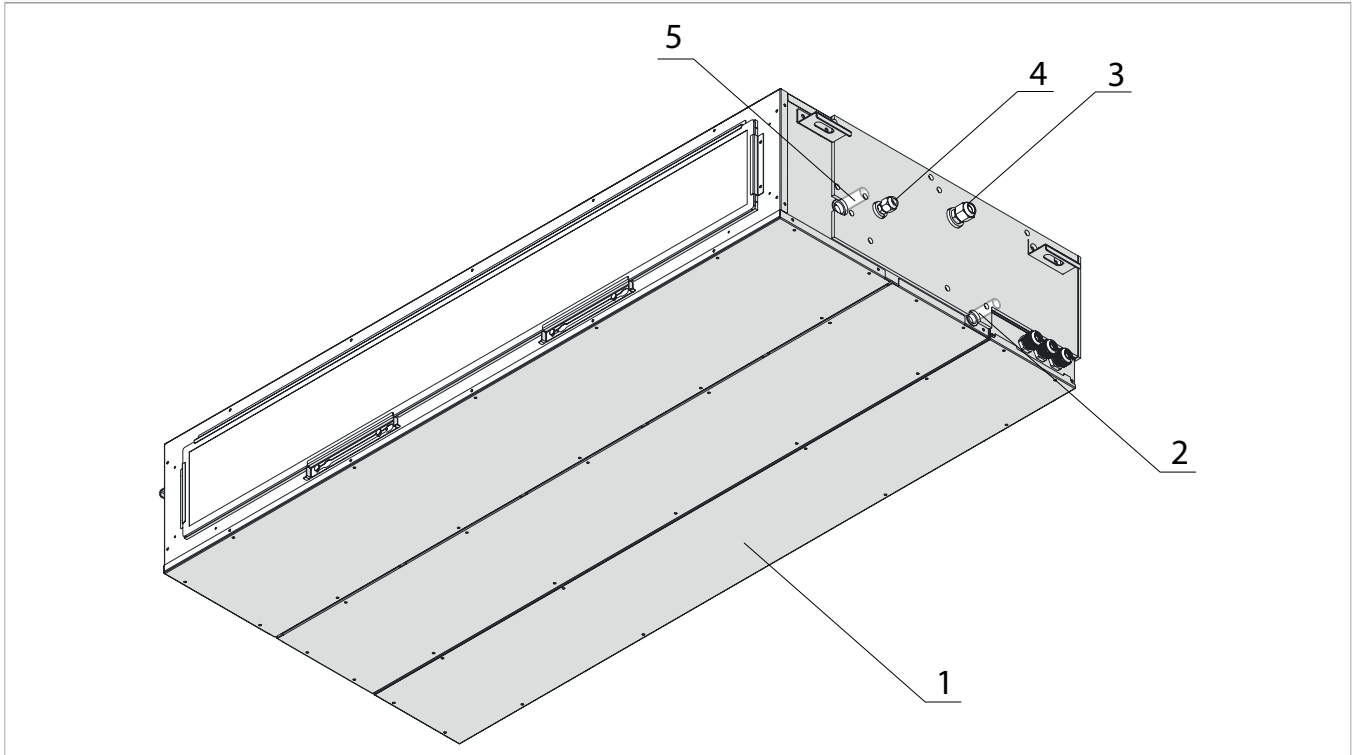

3.5 List of internal components

- 1. Fan
- 2. Direct expansion coil
- 3. Filter

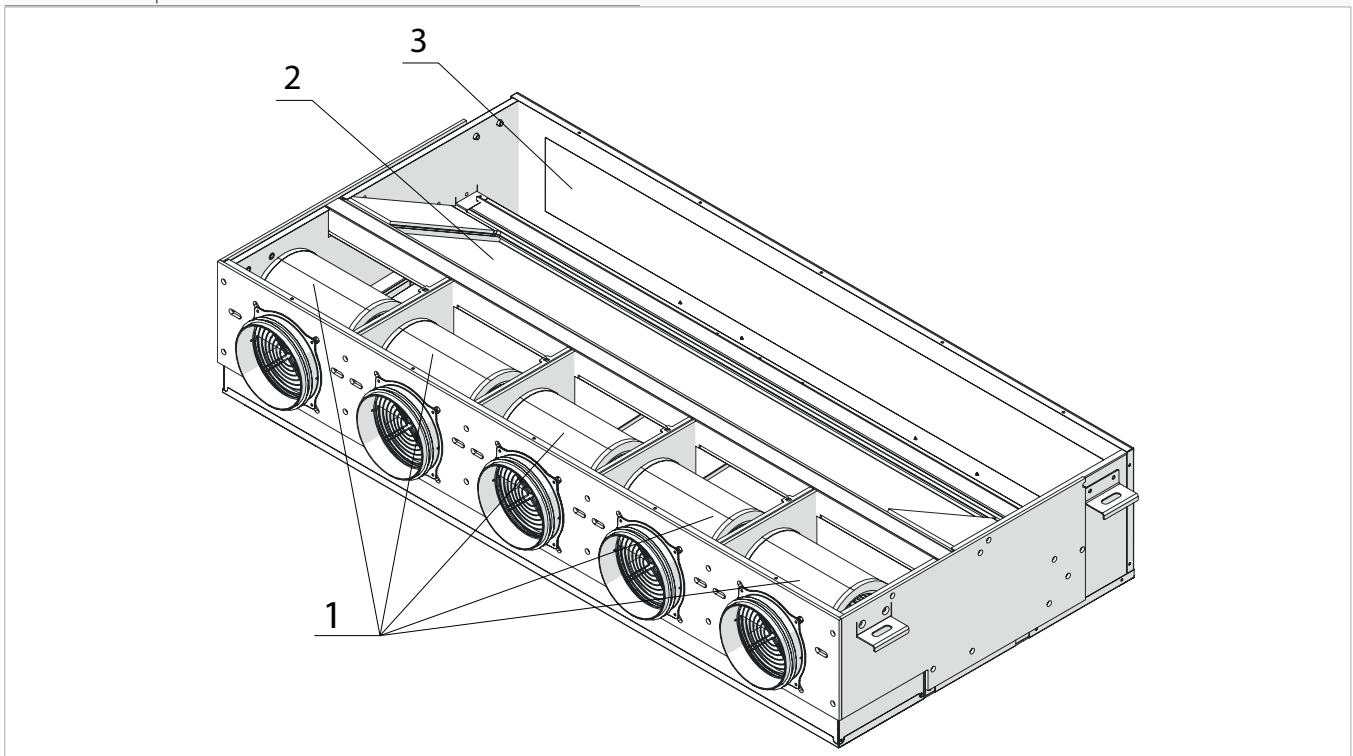

3.6 Configurations

Horizontal installation

- A** Indoor return air rear inlet orientation
- B** Indoor return air underside inlet orientation
- C** Air supply

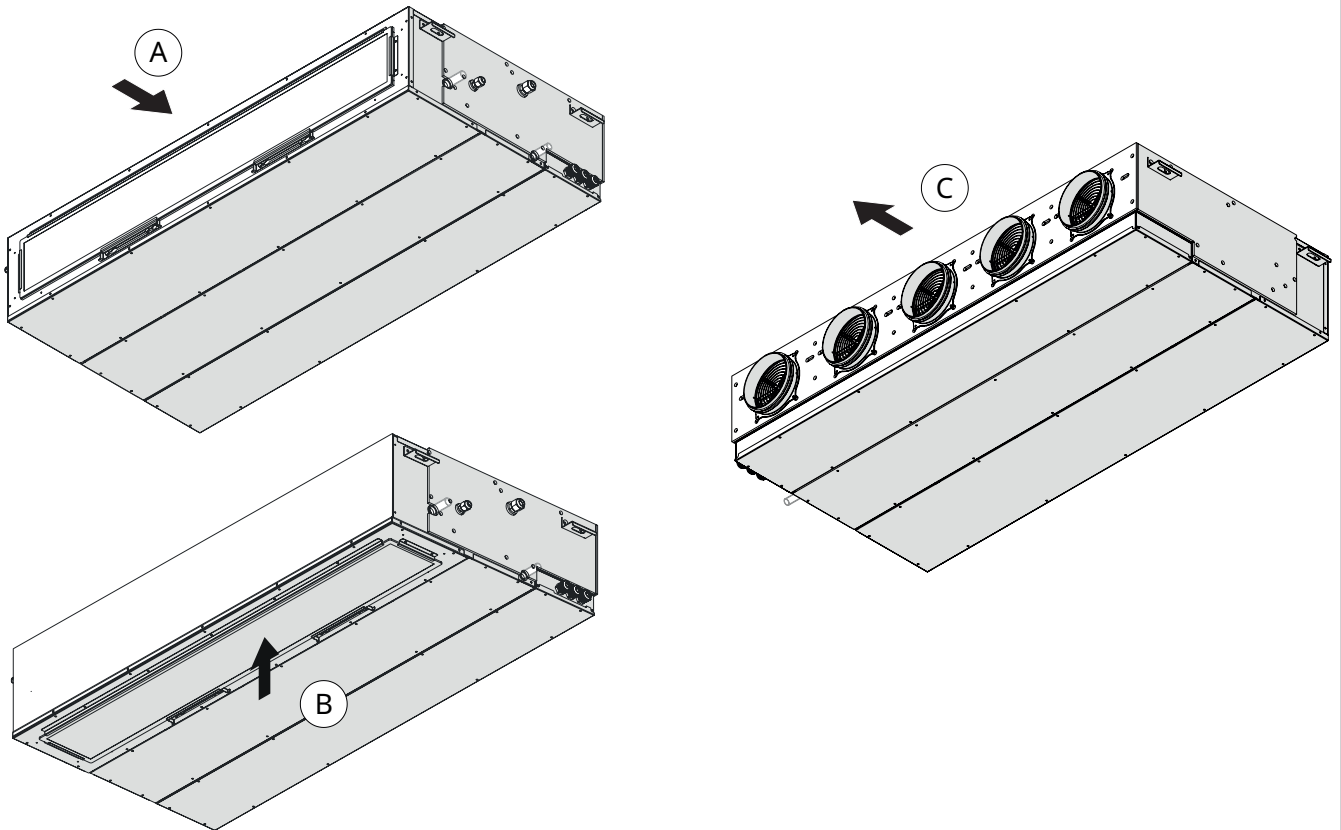

Vertical installation

- A** Indoor return air rear inlet orientation
- B** Indoor return air side inlet orientation

- C** Air supply

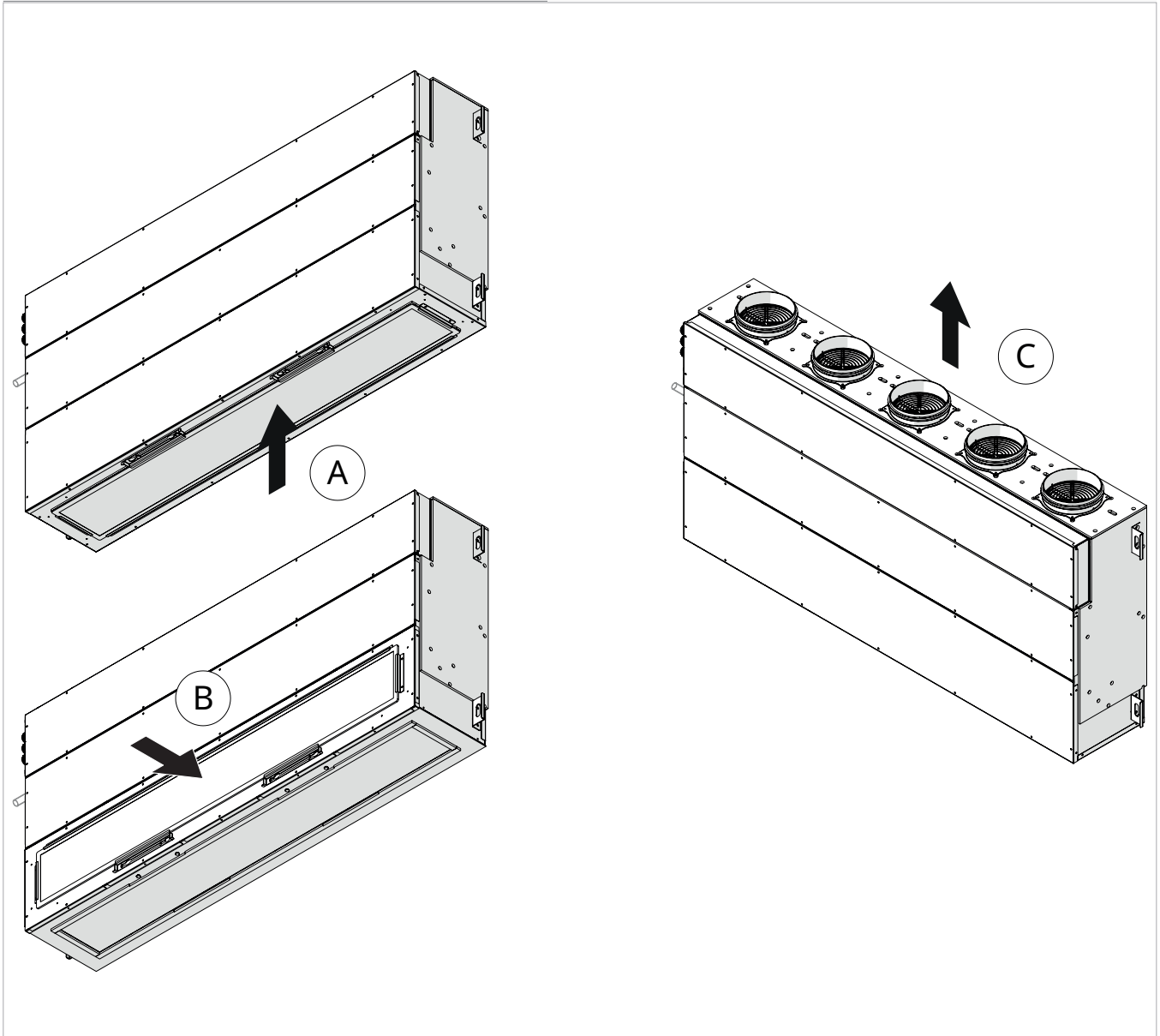

Modification of the extract air configuration

To modify the configuration of the extract air:

1. Blind panel

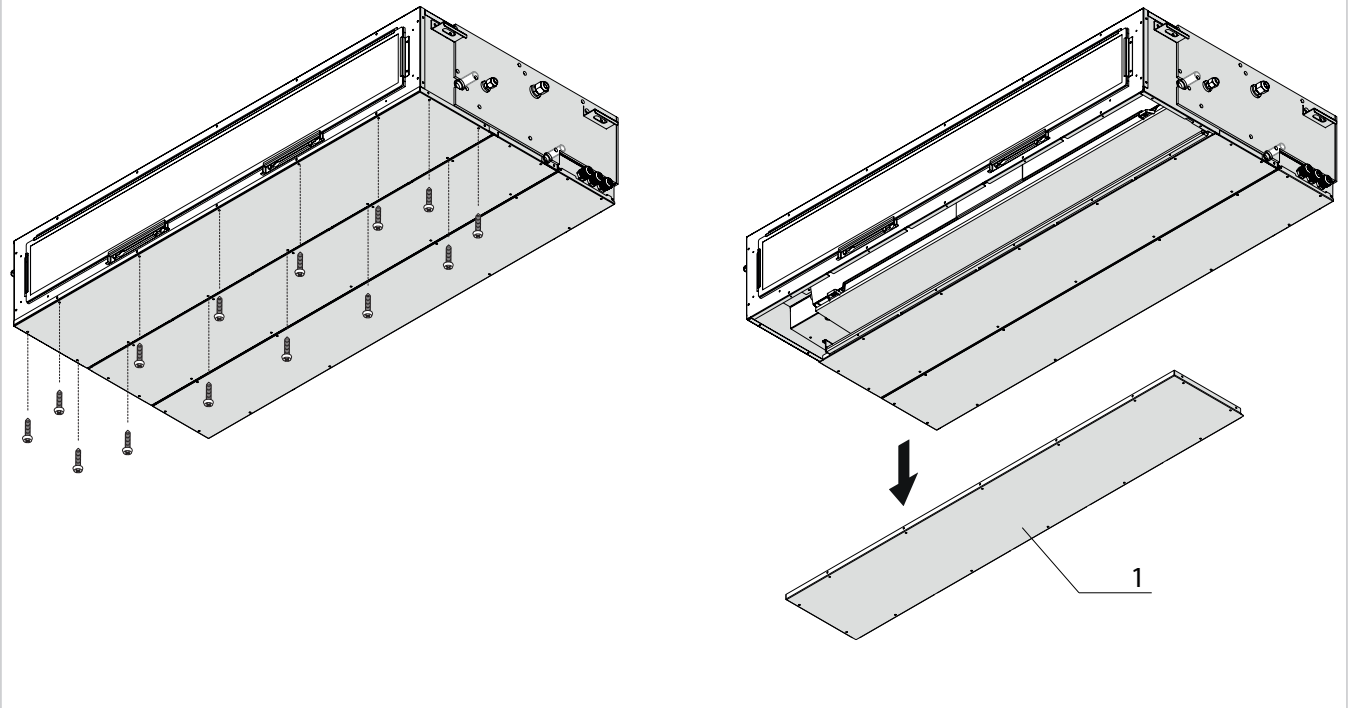

► Remove the screws from the blind panel

► Remove the blind panel

1. Indoor return air panel

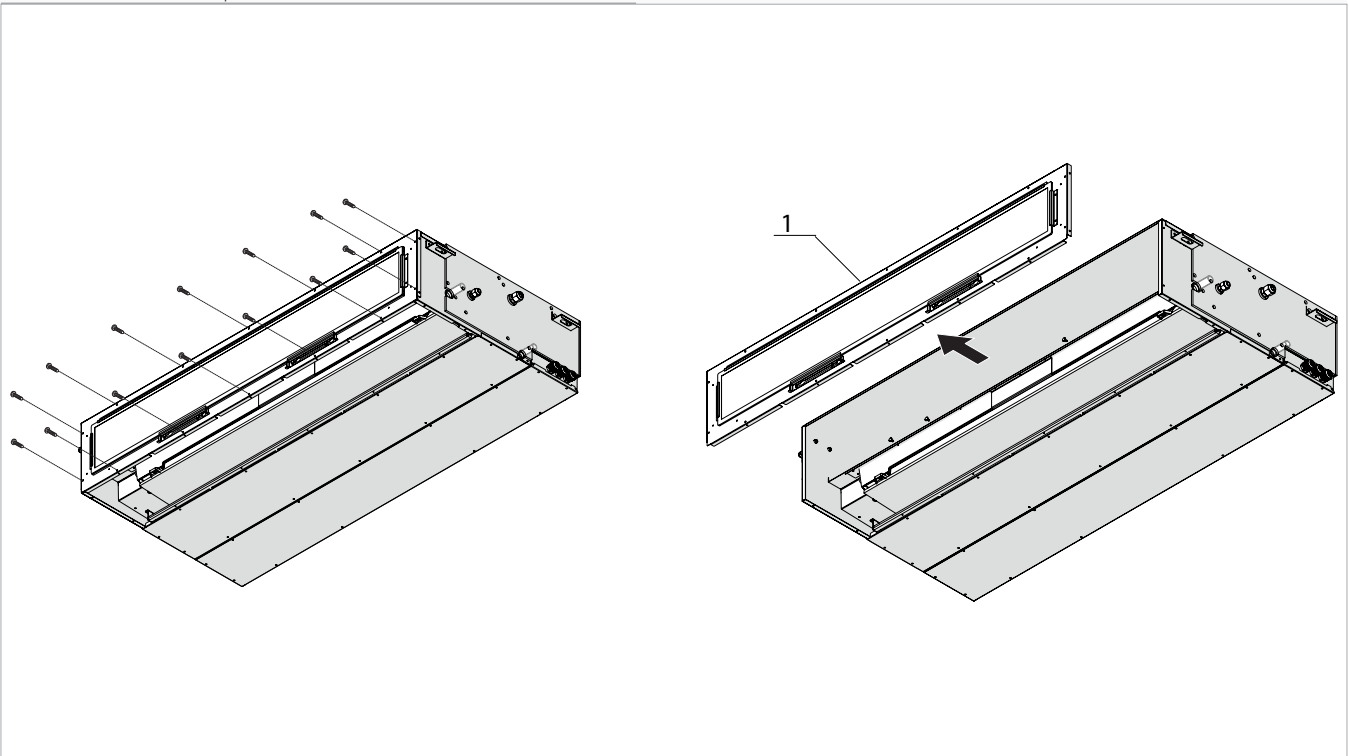

► Remove the screws from the indoor return air panel

► Remove the indoor return air panel

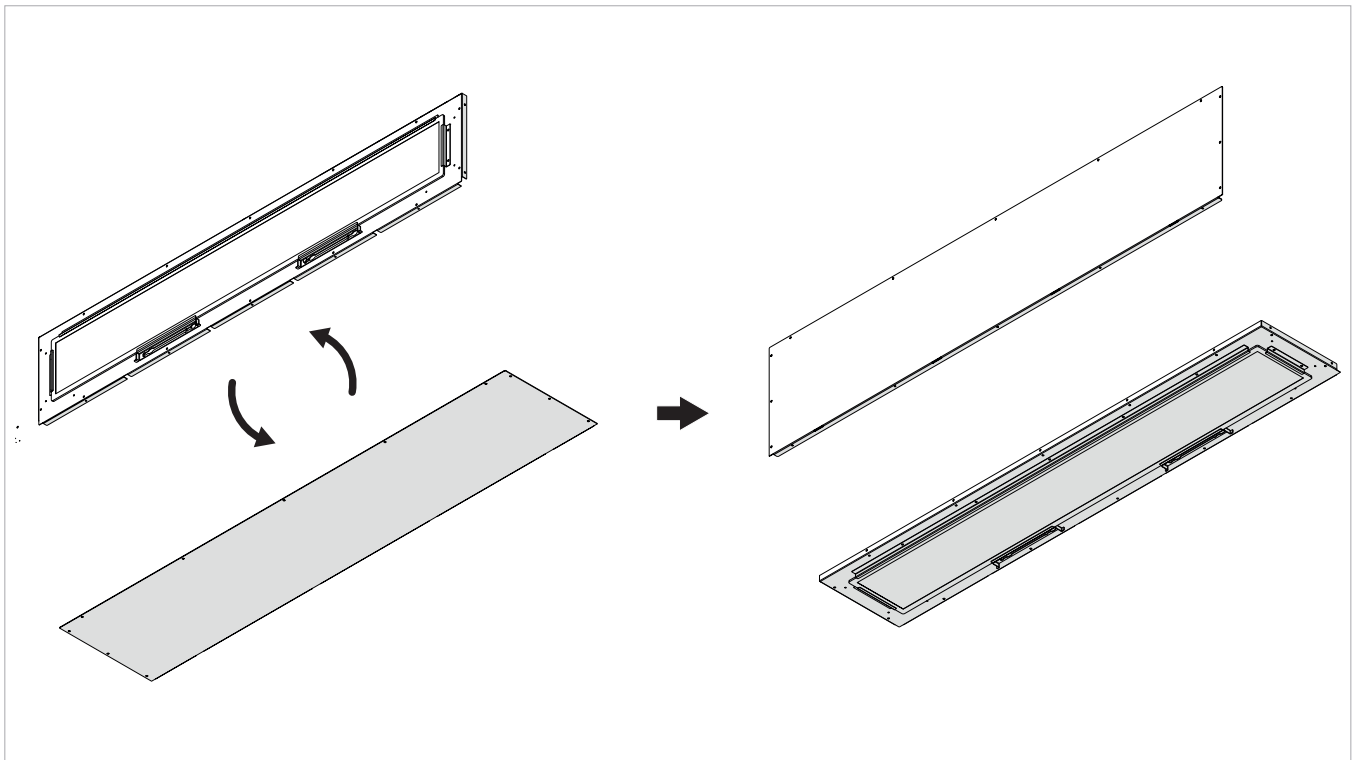

- ▶ Switch the position of the blind panel with the indoor inlet air panel

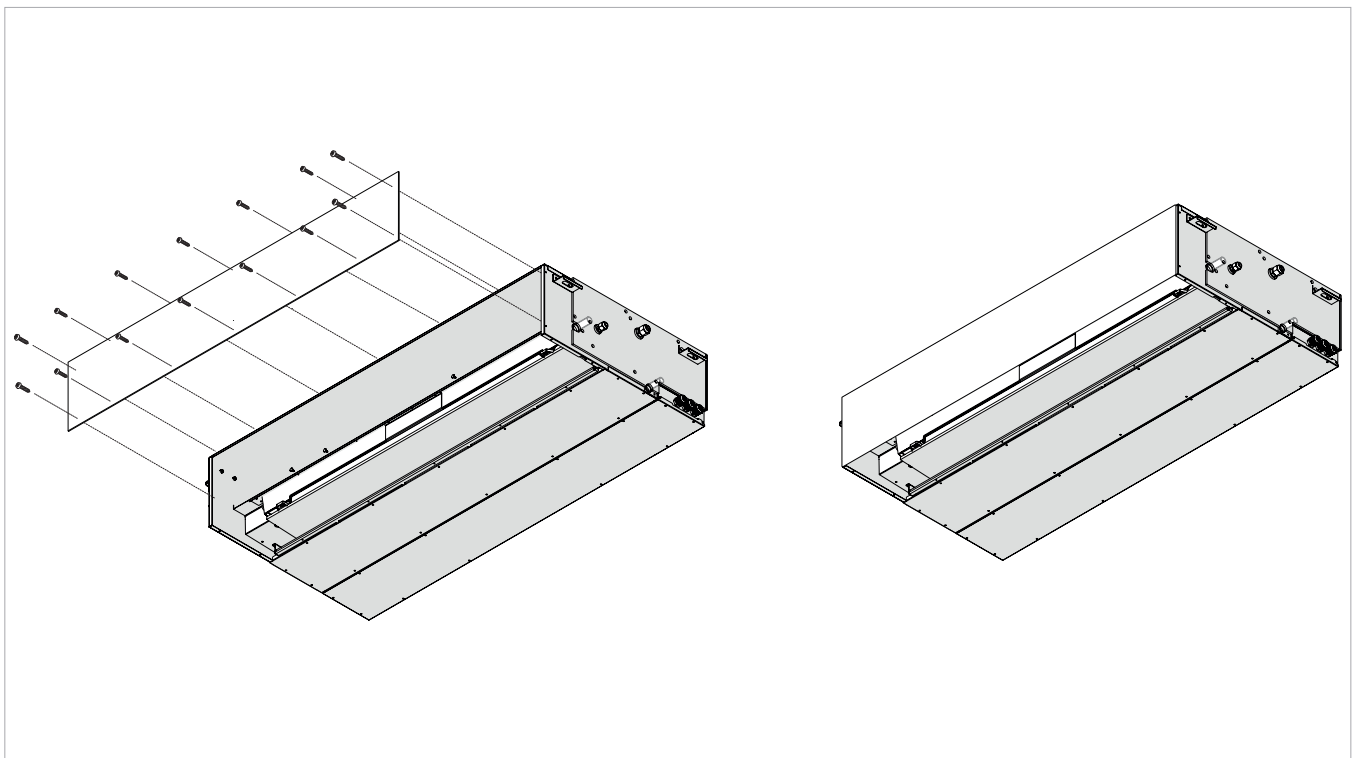

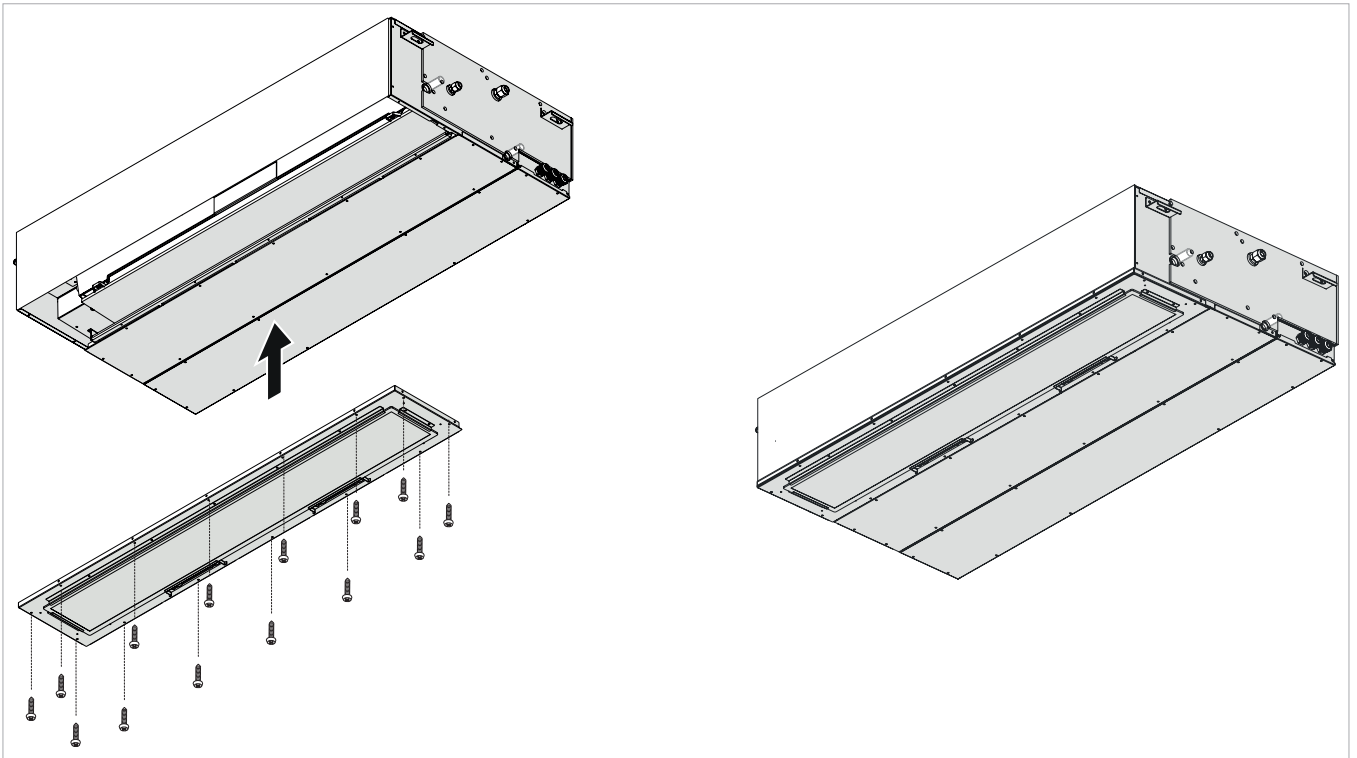

- ▶ Secure the blind panel to the unit
- ▶ Use the previously removed screws

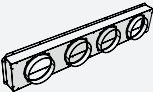
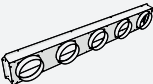
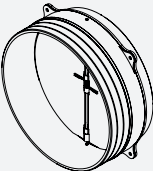
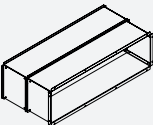
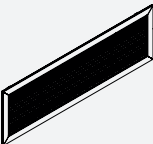
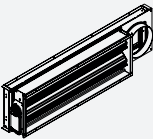
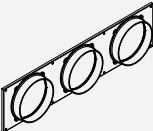
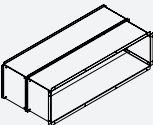

- ▶ Secure the indoor return air panel to the blind panel and to the unit
- ▶ Use the previously removed screws

3.7 Compatible accessories

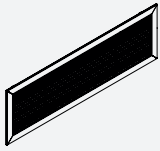
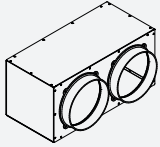
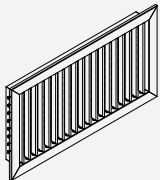
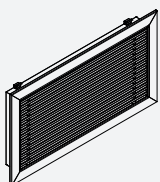
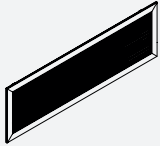
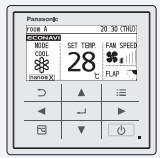
Description		Code
Commands		
	M7 Touch Panel ModBus display	PCZ-EEB749PS
Return manifold with inlets		
	Return manifold with 4 inlets DN 160, model 7110	PCZ-AHRD0468PS
	Return manifold with 5 inlets DN 160, model 1014	PCZ-AHRD0469PS
Non-return damper		
	Non-return damper for FNC MULTI	PCZ-AHRD0519PS
Telescopic kit		
	Telescopic kit (for air suction parts), model 7110	PCZ-AHRD0534PS
	Telescopic kit (for air suction parts), model 1014	PCZ-AHRD0535PS
Grille for telescopic kit		
	Grille for telescopic kit (for air suction parts), model 7110	PCZ-AHRD0544PS
	Grille for telescopic kit (for air suction parts), model 1014	PCZ-AHRD0545PS
Accessories for external air kit		
External air kit		
	External air kit, model 7110	PCZ-AHRD0642PS
	External air kit, model 1014	PCZ-AHRD0643PS
Duct plate kit for external air connection		
	Duct plate kit for external air connection, model 7110	PCZ-AHRD0654PS
	Duct plate kit for external air connection, model 1014	PCZ-AHRD0655PS
Telescopic kit for external air		
	Telescopic kit for external air, model 7110	PCZ-AHRD0664PS
	Telescopic kit for external air, model 1014	PCZ-AHRD0665PS
Grille for telescopic external air kit		

Description		Code
	Grille for telescopic kit for external air, model 7110	PCZ-AHRD0669PS
	Grille for telescopic kit for external air, model 1014	PCZ-AHRD0670PS
Accessories for air distribution		
	Supply/return air manifold 2x DN 160	PCZ-AHRA0708PS
	Aluminium air outlet grille with double row of adjustable blades. White.	PCZ-AHRA0709PS
	Aluminium air supply grille with removable blades and filter. White.	PCZ-AHRA0710PS
Air filters		
	Replacement filter, composed of 1 filter	PCZ-AHRD0493PS
	Replacement filter, composed of 1 filter	PCZ-AHRD0494PS
	Replacement filter, composed of 1 filter	PCZ-AHRD0495PS
Commissioning controls (1)		
	Design wired remote controller	CZ-RTC5B
	CONEX - Wired remote controller	CZ-RTC6 CZ-RTC6BL CZ-RTC6BLW2
	CONEX - Wired remote controller	CZ-RTC6W CZ-RTC6WBL CZ-RTC6WBLW2

- ⚠ To check accessory installation, refer to "Technical characteristics of accessories" *p. 74*
- ⚠ To check compatible accessories, refer to "Accessory pairing" *p. 72*
- ⚠ (1) It is mandatory to install a commissioning controller to ensure correct system operation.

4. INSTALLATION

4.1 Preliminary warnings

- ⚠ **For detailed information on the products, refer to chapter "Technical information" p. 64.**
- ⚠ The installation must be carried out by the installer. There is a risk of refrigerant or water leakage, electric shock or fire if the installation is not performed correctly.
- ⚠ During installation, it is necessary to observe the precautions mentioned in this manual, and on the labels affixed to the inside of the appliances, as well as to take

every precaution suggested by common sense and the safety regulations in force at the place of installation.

- ⚠ Using only the supplied installation-specific components is recommended. Use of alternative components could lead to refrigerant or water leakage, electric shock or fire.
- ⚠ Failure to apply the indicated rules may cause malfunctions of the appliance and relieves the Manufacturer from any warranty and from any damage caused to persons, animals or property.

4.2 Reception

Preliminary warnings

- ⚠ Upon receipt of the package check that it is not damaged, otherwise accept the goods with reservation, producing photographic evidence of any damage.
- ⚠ In the event of damage, notify the shipper by registered mail with return receipt within 3 days of receipt. Presenting photographic documentation, similar information should also be sent by email to the Manufacturer.
- ⚠ No reports of damage will be taken into account later than 3 days after delivery.

Package description

The packaging is made of suitable material and carried out by experienced personnel.

The units are all checked and tested and are delivered complete and in perfect condition.

The appliance is shipped in standard packaging consisting of a cardboard box and a set of polystyrene foam protectors, placed on a wooden pallet and secured with straps.

4.3 Dimensions and weights with packaging

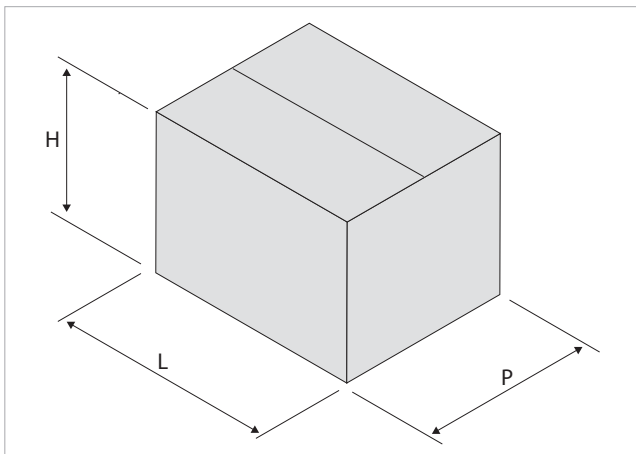

Models	u.m.	4 zones	5 zones
Packaging dimensions			
Width	mm	1.330	1.655
Length	mm	885	790
Height	mm	285	285
Weight	kg	51,0	61,0

4.4 Handling with packaging

Preliminary warnings

- ⚠ The product should only be handled by qualified personnel, adequately equipped, and using tools suitable for the weight and dimensions of the product.
- ⚠ Before each handling operation, check the lifting capacity of the machinery used in accordance with the indications on the packaging.

Handling

With pallet:

- ▶ use a forklift

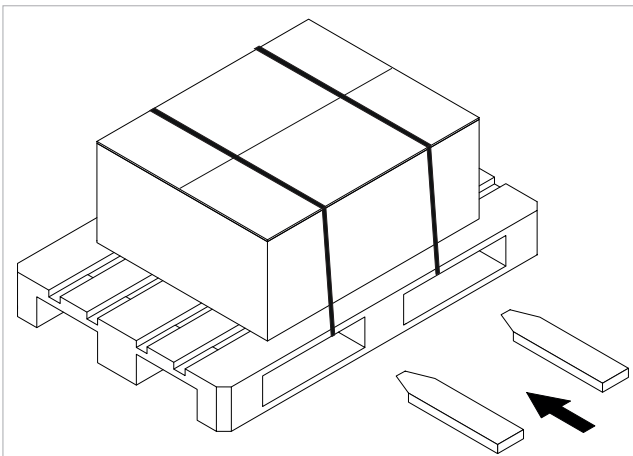

- ⚠ When the load is lifted from the ground, stay clear of the immediate and surrounding area.
- ⚠ Check the information on the packaging for the amount of stackable packages.
- ⚠ In manual operations, the maximum weight per person required by current legislation must always be observed.

Without pallet:

- ▶ use a forklift
- ⚠ The unit can only be moved manually for short trips in exceptional cases. In this case it is necessary to carefully check that the weight of the unit does not exceed what is stipulated by the regulations with respect to the number of persons employed.

4.5 Storage

Preliminary warnings

- ⚠ Stored in accordance with the applicable national regulations.

- ⚠ Store in a closed environment protected from the weather, off the ground by means of sleepers or pallets with temperatures not below 0 °C, up to a maximum of 40 °C.

4.6 Unpacking

Preliminary warnings

- ⚠ Check that the individual components are present.
- ⚠ Check that no components were damaged during transport.
- ⚠ Dispose of the packaging components following the applicable waste disposal regulations. Check for disposal arrangements with your local authority.
- ⚠ Handle with care.
- ⊖ The packing material (cardboard, staples, plastic bags, etc.) must not be dispersed or abandoned in the surrounding environment and must be kept out of reach of children due to risk of hazard.

Removing the packaging

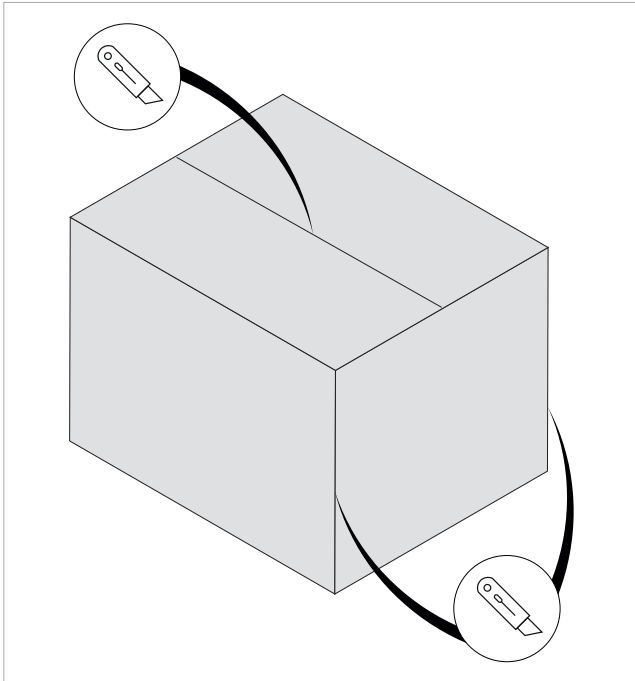

To remove the packaging:

- ▶ Use a cutter
- ▶ Open the cardboard packaging
- ⓘ To aid removal of the product, also cut the vertical edges.
- ▶ Remove the accompanying components
- ▶ Remove the polystyrene elements
- ▶ Remove the appliance from the box

Accompanying material

They are included with the appliance, inside the packaging:

- Installer manual
- Template
- ⚠ Check the presence of the individual components.

4.7 Handling without packaging

Preliminary warnings

- ⚠ The unit must be handled using non-slip gloves.
- ⚠ The product should only be handled by qualified personnel, adequately equipped, and using tools suitable for the weight and dimensions of the product.
- ⚠ Before each handling operation, check the lifting capacity of the machinery used in accordance with the indications on the packaging.
- ⚠ When the load is lifted from the ground, stay clear of the immediate and surrounding area.
- ⚠ Check the information on the packaging for the amount of stackable packages.

- ⚠ In manual operations, the maximum weight per person required by current legislation must always be observed.

Movement methods

- ▶ Remove a fork lift, scaffolding or other suitable lifting system
- ⚠ The unit can only be moved manually for short trips in exceptional cases. In this case it is necessary to carefully check that the weight of the unit does not exceed what is stipulated by the regulations with respect to the number of persons employed.

4.8 Installation site

The location of the appliance must be determined by the plant engineer or a competent person and must take into account both purely technical requirements and any national/local legislation in force.

The appliance is intended to be installed indoors in a horizontal position fixed to the ceiling.

- ⚠ The appliance is declared IPX0 protected, therefore not suitable for installation outdoors or in rooms with the presence of water (swimming pool, etc.).

Preliminary warnings

- ⚠ Avoid installing the unit in the vicinity of:
 - obstacles or barriers that cause recirculation of the exhaust air

- narrow places where the sound level of the appliance can be enhanced by reverberations or resonances
- environments with the presence of flammable or explosive gases
- very damp environments (laundries, greenhouses, bathrooms with high humidity, etc.) to prevent the formation of condensation on the external panels of the unit
- environments with the presence of flammable or explosive gases or flammable fluids
- solar radiation and proximity to heat sources
- ⚠ **Pay particular attention when installing near the sea. Salt-laden atmospheres can cause corrosion and oxidation of internal components, compromising the unit's operation.**

- ⚠ Avoid placing the unit within 1 metre of radio and video equipment.
- ⚠ Do not install above heat sources.
- ⚠ Ensure that:
 - the installation site of the unit must be chosen with the utmost care to guarantee adequate protection from shocks and consequent damage
 - the supporting surface is capable of supporting the weight of the appliance
 - the supporting surface does not affect load-bearing building elements, piping, or power lines
 - the functionality of load-bearing elements is not compromised
 - there are no obstacles to the free circulation of air through the holes (plants, leaves...)

- the appliance must be installed in a position where it can be easily serviced
- the safety distances between the units and other appliances or structures are scrupulously respected so that the air entering and leaving the fans is free to circulate
- ⚠ If the unit is installed incompletely or on an unsuitable surface, it could cause damage to persons or property if it becomes detached.
- ⚠ The appliance must not be in a position where the air flow is aimed directly at a person.
- ⚠ Provide the following:
 - a drain nearby for the outflow of condensation
 - a compliant power supply nearby
 - fastening elements suitable for the type of support

4.9 Minimum installation distances

The clearance zones for the installation and maintenance of the appliance are shown in the figure below. Established spaces are necessary to avoid barriers to airflow and allow for normal cleaning and maintenance.

- ⚠ Make sure that there is sufficient space to allow the panels to be removed for routine and supplementary maintenance operations.

Horizontal installation

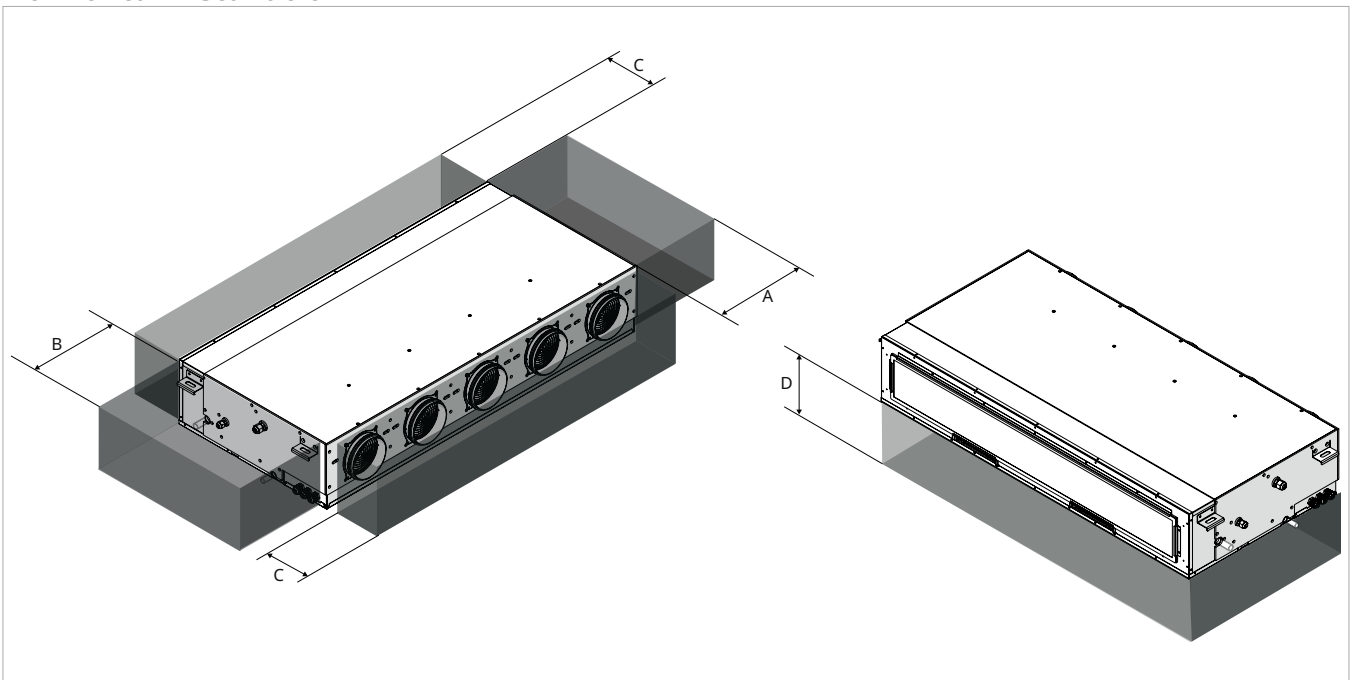

Vertical installation

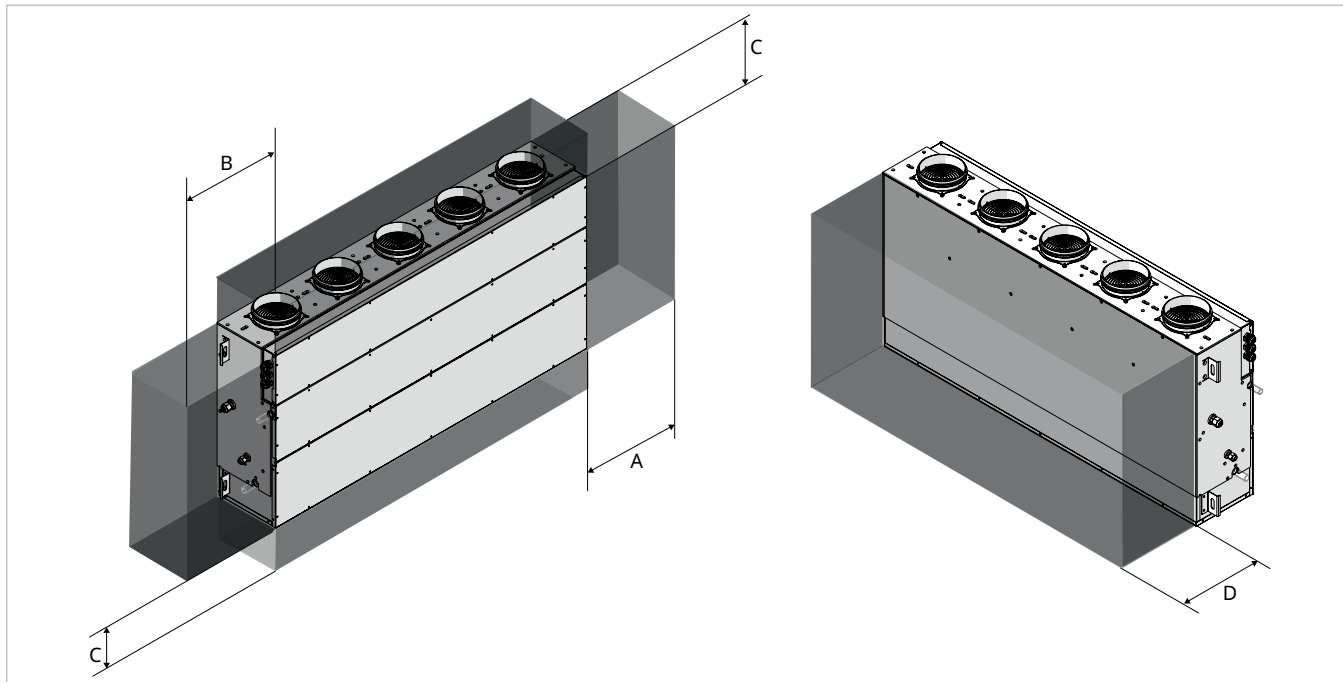

Models	u.m.	4 zones	5 zones
Minimum distances			
A	mm	50	50
B	mm	350	350
C	mm	70	70
D	mm	250	250

Hatch dimensions

⚠ For installation in a ceiling, it is mandatory to create an access hatch for the inspection and maintenance of the device.

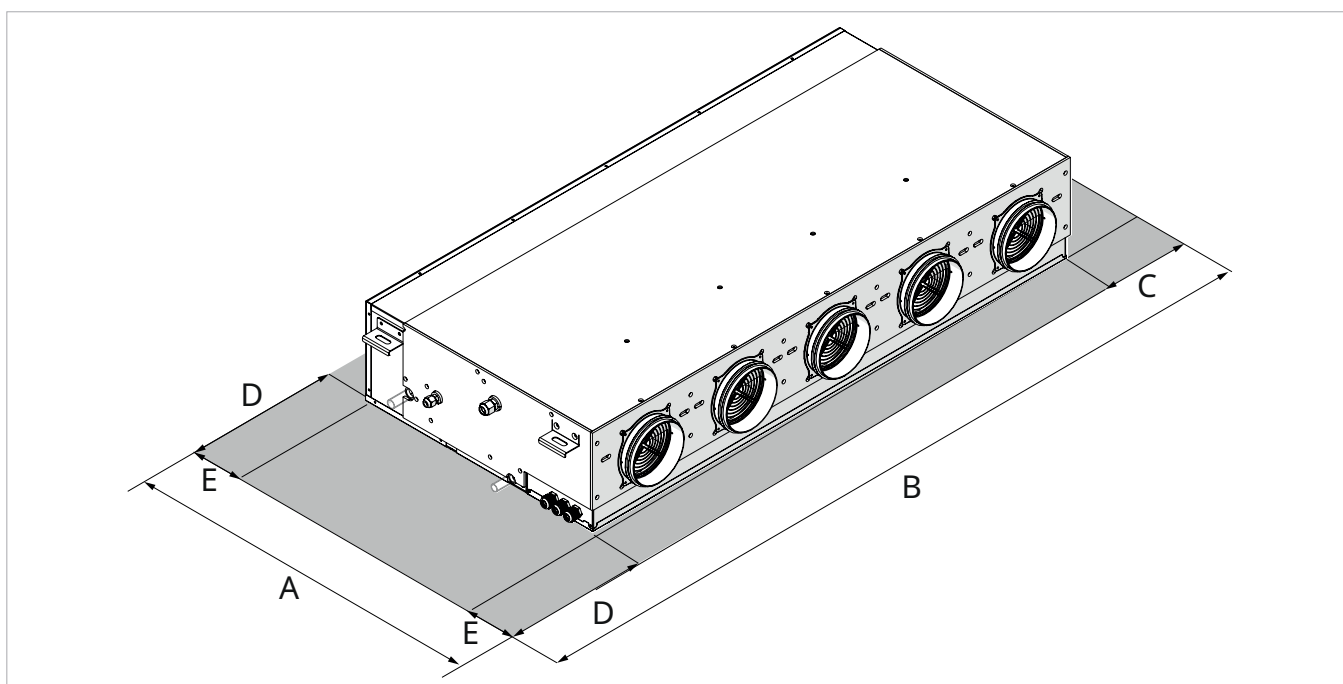

Models	u.m.	4 zones	5 zones
Hatch dimensions			
A	mm	795	795
B	mm	1.890	2.140
C	mm	50	50
D	mm	350	350
E	mm	50	50

4.10 Positioning

Preliminary warnings

⚠ Check that:

- the surface supports the weight of the appliance
- the surface does not affect piping or power lines
- the functionality of load-bearing elements is not compromised

Positioning the unit

1. Mounting holes

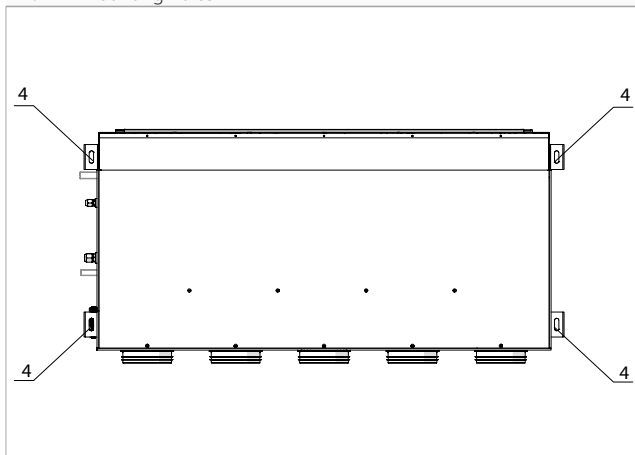

⚠ Use the 4 mounting slots on the top side of the unit.

Horizontal installation

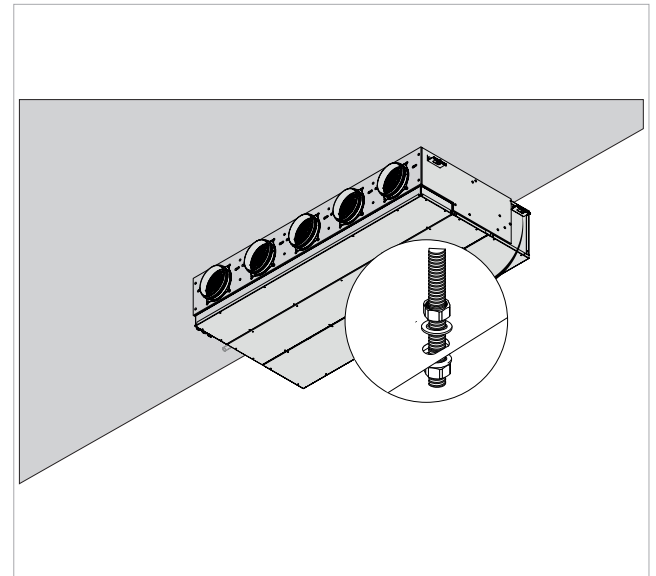

Vertical installation

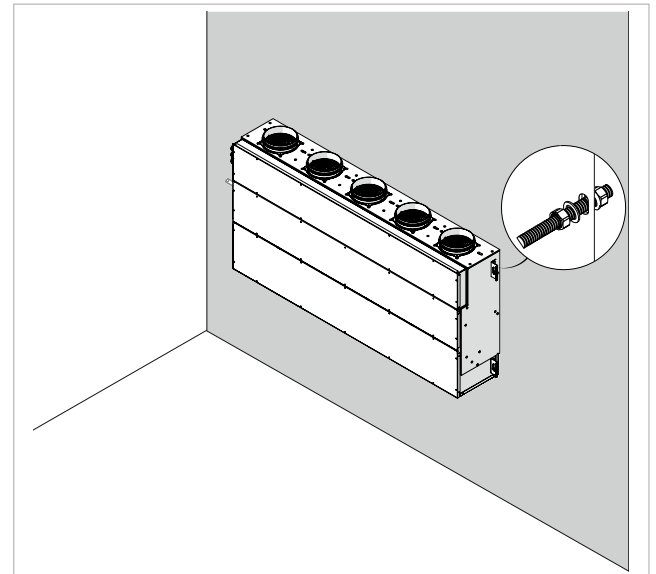

- ⚠ Check the correct orientation of the unit.
- ⚠ Use anti-vibration dampers under the support points
- ▶ Mark the position of the fixing holes
- ▶ use the installation template to drill the wall

- ▶ Use fixing systems appropriate for the type of supporting surface and the weight of the unit
- ▶ Secure the unit to the fixing system

Check that:

- it is levelled
- the minimum installation distances are respected

Model	Refrigerant charge (kg)	
	Min	Max
U-71PZ3E5A	1,32	1,49
U-100PZ3E5	2,40	3,30
U-125PZ3E5	2,80	3,70
U-140PZ3E5	2,80	3,70
U-100PZ3E8	2,40	3,30
U-125PZ3E8	2,80	3,70
U-140PZ3E8	2,80	3,70

Minimum floor area - 4 Zone (U-71PZ3E5A)				
M (kg)	Unit installation height (m)			
	2,2	2,5	3,0	3,5
	Amin (m ²)			
1,32	No limit			
1,49				

Minimum floor area - 4 Zone (U-100PZ3E5 / U-100PZ3E8)				
M (kg)	Unit installation height (m)			
	2,2	2,5	3,0	3,5
	Amin (m ²)			
2,40	3,6	2,8	2,0	1,4
2,45	3,8	2,9	2,0	1,5
2,50	4,0	3,1	2,1	1,6
2,55	4,1	3,2	2,2	1,6
2,60	4,3	3,3	2,3	1,7
2,65	4,4	3,4	2,4	1,8
2,70	4,6	3,6	2,5	1,8
2,75	4,8	3,7	2,6	1,9
2,80	5,0	3,8	2,7	2,0
2,85	5,1	4,0	2,8	2,0
2,90	5,3	4,1	2,9	2,1
2,95	5,5	4,3	3,0	2,2
3,00	5,7	4,4	3,1	2,3
3,05	5,9	4,6	3,2	2,3
3,10	6,1	4,7	3,3	2,4
3,15	6,3	4,9	3,4	2,5
3,20	6,5	5,0	3,5	2,6
3,25	6,7	5,2	3,6	2,6
3,30	6,9	5,3	3,7	2,7

Minimum floor area - 5 Zone (U-100PZ3E5 / U-100PZ3E8 / U-125PZ3E5 / U-125PZ3E8 / U-140PZ3E5 / U-140PZ3E8)				
M (kg)	Unit installation height (m)			
	2,2	2,5	3,0	3,5
	Amin (m ²)			
2,40	3,6	2,8	2,0	1,4
2,45	3,8	2,9	2,0	1,5
2,50	4,0	3,1	2,1	1,6
2,55	4,1	3,2	2,2	1,6
2,60	4,3	3,3	2,3	1,7
2,65	4,4	3,4	2,4	1,8
2,70	4,6	3,6	2,5	1,8
2,75	4,8	3,7	2,6	1,9
2,80	5,0	3,8	2,7	2,0
2,85	5,1	4,0	2,8	2,0
2,90	5,3	4,1	2,9	2,1
2,95	5,5	4,3	3,0	2,2
3,00	5,7	4,4	3,1	2,3
3,05	5,9	4,6	3,2	2,3
3,10	6,1	4,7	3,3	2,4
3,15	6,3	4,9	3,4	2,5
3,20	6,5	5,0	3,5	2,6
3,25	6,7	5,2	3,6	2,6
3,30	6,9	5,3	3,7	2,7
3,35	7,1	5,5	3,8	2,8
3,40	7,3	5,7	3,9	2,9
3,45	7,5	5,8	4,1	3,0
3,50	7,8	6,0	4,2	3,1
3,55	8,0	6,2	4,3	3,2
3,60	8,2	6,4	4,4	3,2
3,65	8,4	6,5	4,5	3,3
3,70	8,7	6,7	4,7	3,4

4.11 Refrigeration connections

Preliminary warnings

- ⚠ **The installer must comply with Regulation 303/2008/EC, which, in accordance with Directive 842/2006/EC, defines the requirements for companies and personnel concerning the fixed refrigeration, air conditioning, and heat pump equipment containing certain fluorinated greenhouse gases.**
- ⚠ Use equipment suitable for the system refrigerant.
- ⚠ Identify the piping route to minimise tubing length and bends, maximising system efficiency.
- ⚠ The refrigerant lines should be as straight as possible, and any necessary bends must have a radius greater than 40 mm.

- ⚠ Use exclusively copper pipes specifically designed for refrigeration.
- ⚠ The pipes must be supplied clean and sealed at the ends. It is possible to use pre-insulated copper pipes for refrigeration.
- ⚠ The pipes must not contain residues of debris, dirt, or water that could damage the components of the unit and compromise the proper functioning of the appliance.
- ⚠ Handle the refrigerant with care. Leaking refrigerant can cause frostbite.

- ⚠ For safety and installation requirements relating to the outdoor unit and overall system installation, please refer to the relevant outdoor unit documentation.
- ⊖ It is forbidden to use pipes with a diameter different from that indicated in the technical data table.
- ⊖ Using refrigerant lines that have been previously used is prohibited as the seal at the flare connection cannot be guaranteed.
- ⊖ Connecting using regular hydraulic pipes is prohibited.
- ⊖ Welding is prohibited in the presence of refrigerant within the refrigeration circuit. If necessary, the refrigerant must be recovered, and the circuit cleaned using oxygen-free nitrogen.

Specific warnings for R32

- ⚠ The length of the connecting pipes must be minimised.
- ⚠ Connecting pipes must be shielded from physical damage and should not be installed in an unventilated space smaller than the area specified in the Minimum Floor Area table.
- ⚠ The connecting pipes must be installed in a position unlikely to be exposed to corrosive substances, unless they are made from materials inherently corrosion-resistant or adequately protected against corrosion.
- ⚠ Compliance with national regulations for the gas used is mandatory.
- ⚠ Refrigerant connections must be accessible for maintenance purposes.
- ⚠ Work must be undertaken following a controlled procedure to minimise the risk of presence of flammable gases or vapors while the work is being carried out.
- ⊖ Performing hot work (welding, brazing, etc.) is prohibited.
- ⚠ To make refrigerant connections, the following precautions must be taken:

Area checks

- Perform safety checks to ensure that the risk of combustion is minimised
- avoid working in confined spaces
- delimit the area around the workspace
- ensure safe working conditions around the area by checking for flammable materials

Refrigerant fluid presence checks

- the area must be checked with a specific refrigerant fluid detector before and during work, so the technician is aware of potentially flammable atmospheres
- ensure that the leak detection apparatus is suitable for use with flammable refrigerants, meaning it does not produce sparks, is properly sealed, or inherently safe
- ⊖ Using combustion-based refrigerant fluid detectors, such as a halide torch or any other system using an open flame, is prohibited.

Combustion source checks

- people performing work on a refrigeration system involving exposed piping containing or having contained a flammable refrigerant fluid must refrain from using any combustion source that could lead to the risk of fire or explosion

- all potential combustion sources, including smoking a cigarette, must be kept sufficiently far from the work area during operations in which flammable refrigerant fluid could be released into the surrounding space
- check the surrounding area of the equipment to ensure there are no fire hazards or combustion risks
- place signs stating "No Smoking"

Ventilation area checks

- ensure the area is adequately ventilated
- during work, there must be a continuous level of ventilation
- ventilation should safely disperse any released refrigerant fluid and preferably expel it outside into the atmosphere

Leak detection

- ⊖ Using combustion-based refrigerant fluid detectors, such as a halide torch or any other system using an open flame, is prohibited.
- ⚠ For leak detection, follow the following instructions:
 - use electronic detectors to search for flammable refrigerant fluids
 - before usage, ensure the detectors are properly calibrated
 - calibration operations must be carried out in an area free from refrigerant fluid
 - ensure the detector is not a potential ignition source and is suitable for the refrigerant fluid used
 - if a leak is suspected, all open flames must be eliminated
 - in the event of a leak requiring brazing, it is mandatory to recover all refrigerant fluid from the system or isolate it (using shut-off valves) in a part of the system away from the leak
- ⚠ The use of silicone sealant can compromise the effectiveness of certain types of leak detection instruments.

Recharge procedure

- ⚠ For the recharge procedure, ensure that:
 - there is no contamination between different refrigerant fluids
 - the charging equipment's flexible hoses are as short as possible to minimise the amount of refrigerant fluid
 - the cylinders are kept in an upright position
 - ground the refrigeration system before proceeding with the charge
- ⚠ Before proceeding with the charge, ensure that the leak check has been performed.
- ⚠ Check for refrigerant leaks before leaving the site.
- ⚠ Label the system with the refrigerant charge when the charge is complete.
- ⊖ Overloading the refrigeration circuit is prohibited.
- ⊖ It's prohibited to introduce a refrigerant fluid into the system other than the one indicated or to mix different refrigerant fluids.

Connection diagram

1. Liquid line
2. Gas line

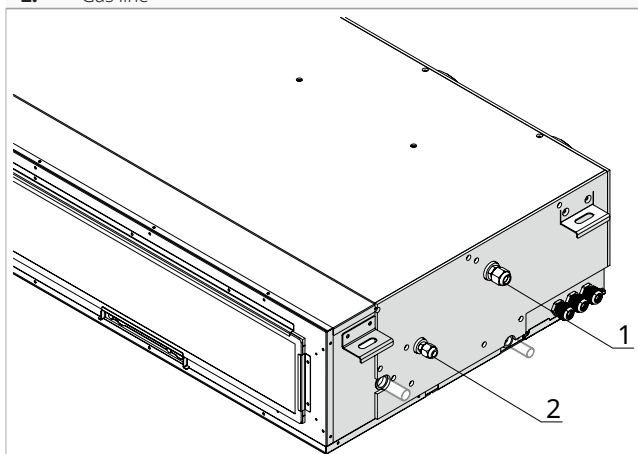

Piping connection

The refrigerant fittings, equipped with shut-off valves, are designed for flare or solder connections.

Preliminary warnings

- ⚠ Mount a cable duct (preferably with internal separators) of suitable dimensions on the wall to later pass the pipes and electrical cables through.
- ⚠ Cut the pipe sections with an excess of approximately 3-4 cm in length.
- ⚠ Immediately after cutting and deburring, seal the tube ends with insulating tape.
- ⚠ Remove any burrs using the appropriate tool.
- ⚠ Make the cut solely using a tube cutter wheel, tightening at small intervals to avoid crushing the pipe.
- ⚠ **Never use a regular saw to cut the pipes; debris could enter the pipe and later circulate within the system, causing severe damage to the components.**
- ⚠ Avoid the introduction of non-condensable gases (such as air) into the circuit; otherwise, during operation, high pressures might occur, risking ruptures.

Flare connection

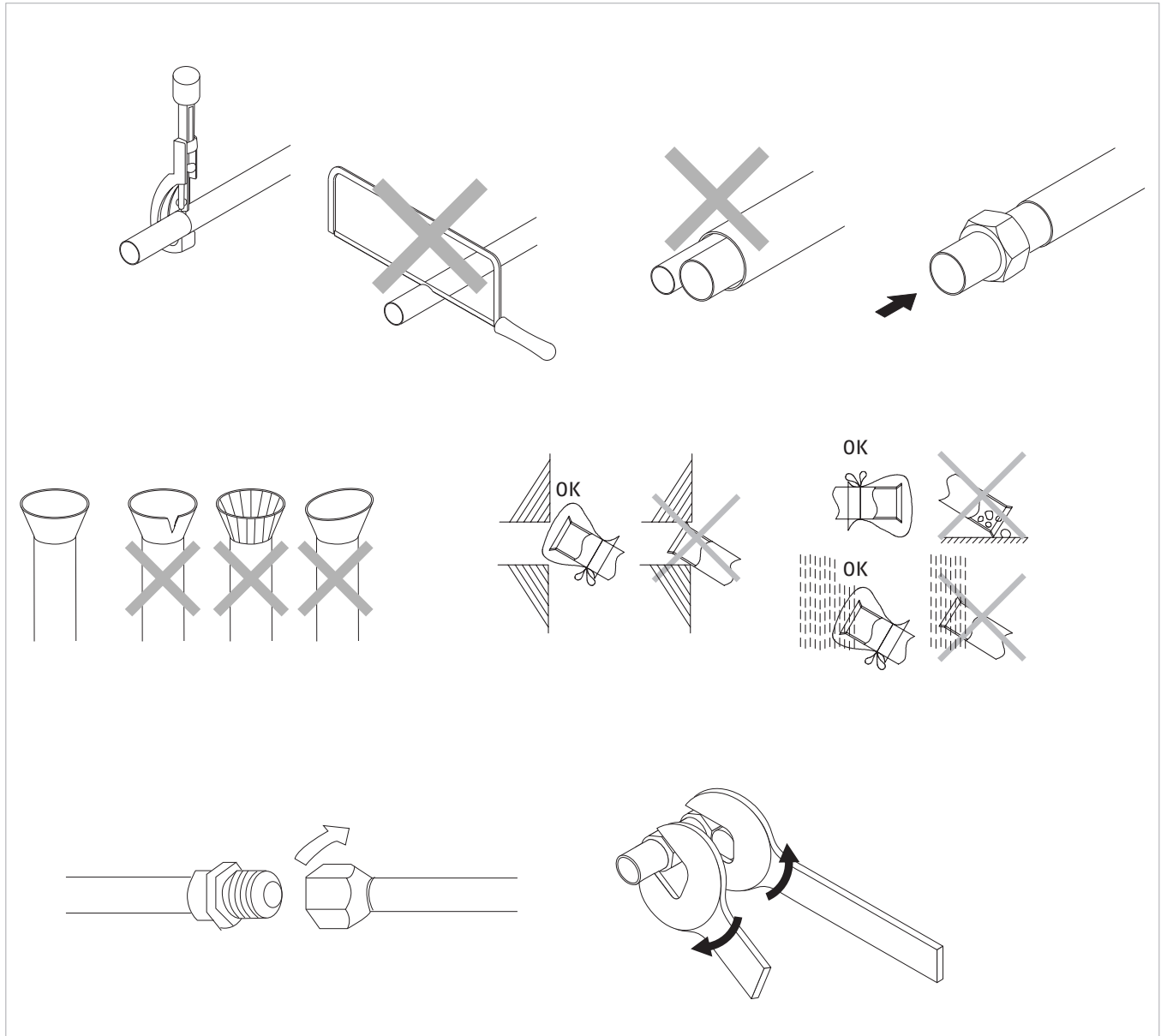

Before connecting:

- ▶ Insert the fastening nut into the tube
- ▶ Perform deburring on the tube ends using the appropriate tool
- ▶ Lubricate the thread of the fitting with refrigerant oil
- ⚠ Do not use any other type of lubricant.
- ⚠ The deburring must not have any breaks, cracks, or splintering.
- ⚠ Avoid using refrigerant oil on the outer part of the flare.

To connect:

- ▶ Position the refrigerant lines
- ▶ Hand-tighten the tube nut onto the fitting thread
- ▶ Use a wrench to hold the threaded part of the fitting steady
- ▶ Use a torque wrench on the nut to securely tighten it
- ⚠ Keep the leak detector device on near the unit during the connection process to detect any refrigerant leaks promptly.

⚠ For subsequent operations, refer to the manual of the paired outdoor unit.

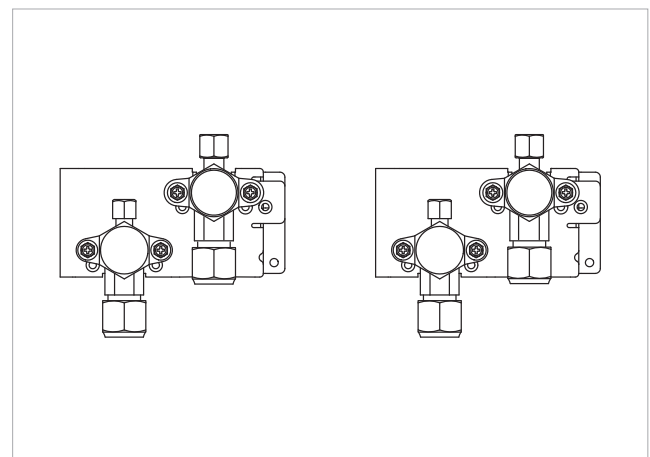

Pipe Ø		Tightening torque
mm	inches	Nm
6,35	1/4	18
9,52	3/8	42
12,70	1/2	55
15,88	5/8	60

4.12 Condensate drain connection

Preliminary warnings

- ⚠ This appliance is equipped with trays for collecting the condensate that is produced during operation. Condensate must be routed to a suitable place for drainage.
- ⚠ If the drainage line runs into a container (tank or other) it must be ensured that the container itself is hermetically sealed and most importantly it must be ensured that the drainage pipe is not immersed in water.
- ⚠ The hole for the condensate pipe must always have a downwards slope.
- ⚠ When connecting the condensate drain, take care not to crush the rubber pipe.

Attachment position

The unit has two condensate drains. The size and position of the condensate drain attachments are shown below.

1. Condensate drain for vertical installation
2. Condensate drain for horizontal installation

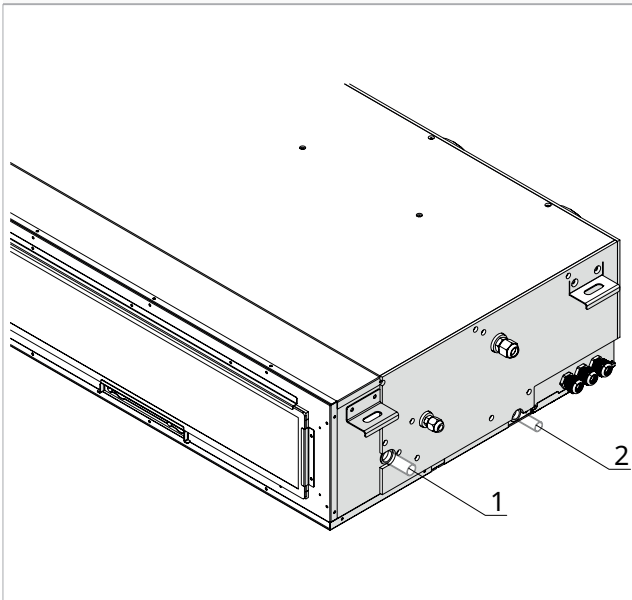

Connections

1. Condensate drain connection
2. Condensate drain pipe
3. Hose fitting
4. Hose clamp

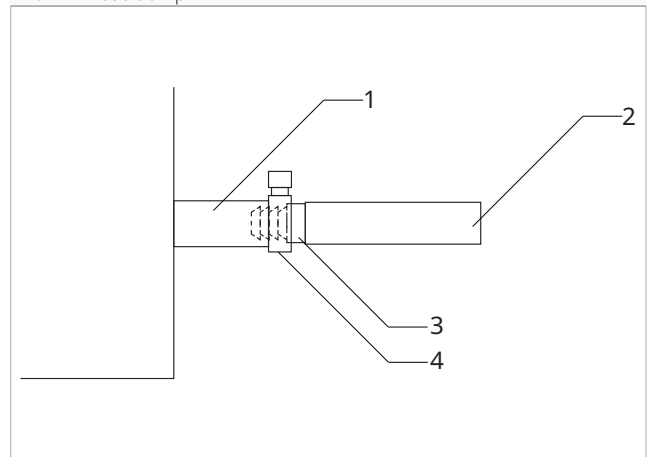

1. Unit

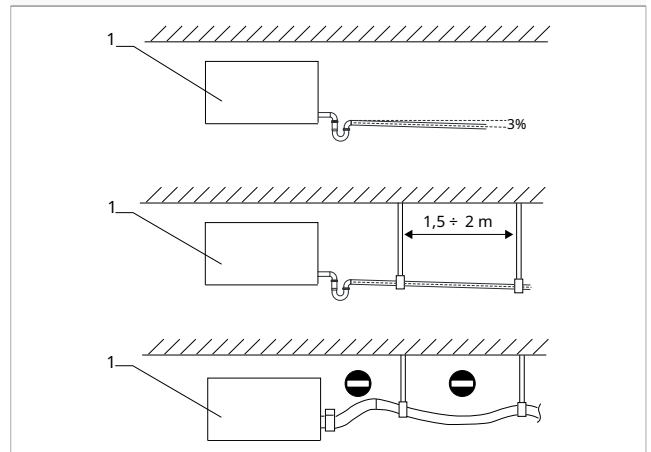

HT	100 mm
H1	50 mm
H2	50 mm

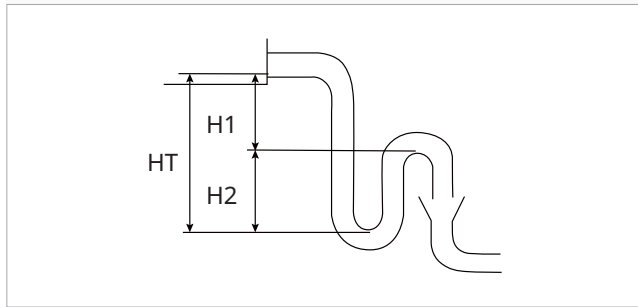

To connect the condensate drain:

- ▶ Connect the drainage pipe to the connection provided on the unit
- ▶ Install a siphon on the condensate drainage pipe near the unit
- ▶ Direct the condensate drain pipe to a suitable place for draining
- ▶ Maintain a minimum slope of 3% towards the drain location

- ▶ Insulate junction points

- ⚠ **It is mandatory to install an adequate siphon on the condensate drainage pipe to prevent the negative pressure generated by the fans from obstructing the proper flow of condensate, which could lead to spillage inside the premises.**
- ⚠ The drainage system must include a suitable siphon to prevent unwanted air from entering the vacuum system. The siphon also prevents the entry of odours or insects.
- ⚠ The siphon must be fitted with a plug at the bottom or must in any case permit quick dismantling for cleaning.
- ⚠ Use plastic drainage pipes.
- ⚠ Avoid metal pipes.
- ⚠ Make sure all joints are sealed to prevent leakage of water.
- ⚠ Condensate drain pipes must be insulated for both indoor and outdoor sections to avoid condensation on the surface and/or frosting problems. The insulation must be inserted all the way to the condensate drain pipe connection on the unit.
- ⚠ Use pipes with a diameter of 40 mm.

4.13 Aeraulic connections

Preliminary warnings

- ⚠ The sizing of ducting and supply and extract grilles must be carried out by a professionally qualified person.
- ⚠ To prevent the transmission of any vibrations of the machine into the room, an anti-vibration joint should be placed between the fan outlets and the ducts.
- ⚠ The connecting pipes must be of a suitable diameter and supported so that their weight does not put strain on the appliance.

Connections

Horizontal installation

- A** Indoor return air rear inlet orientation
B Indoor return air underside inlet orientation

- C** Air supply

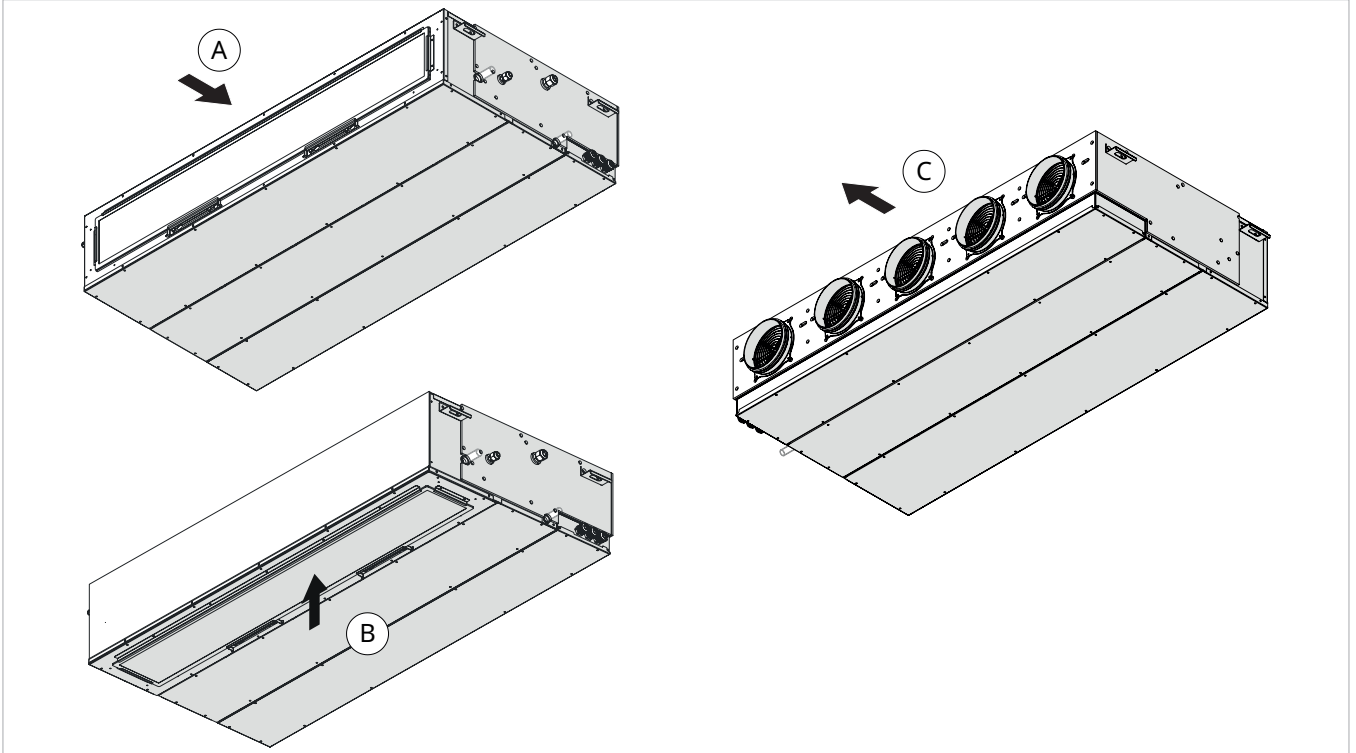

Vertical installation

- A** Indoor return air rear inlet orientation
B Indoor return air side inlet orientation

- C** Air supply

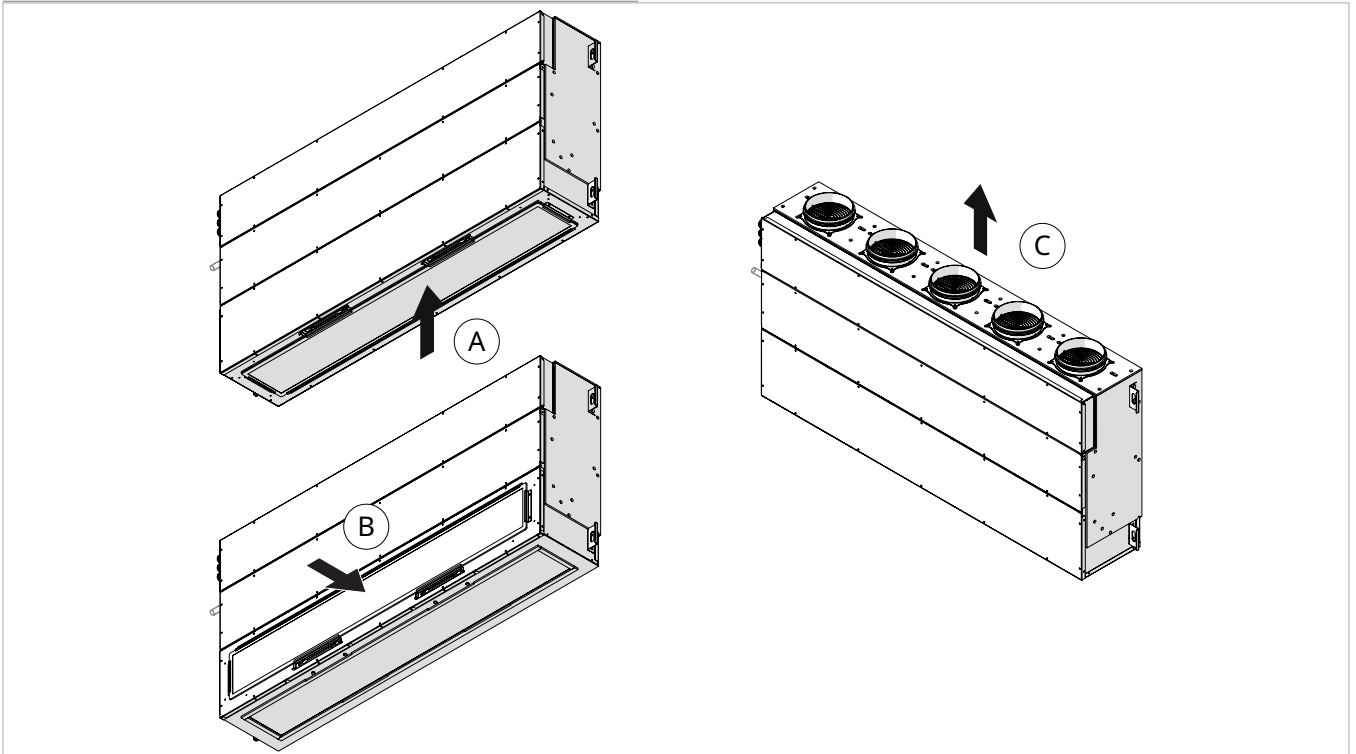

Extract air dimensions

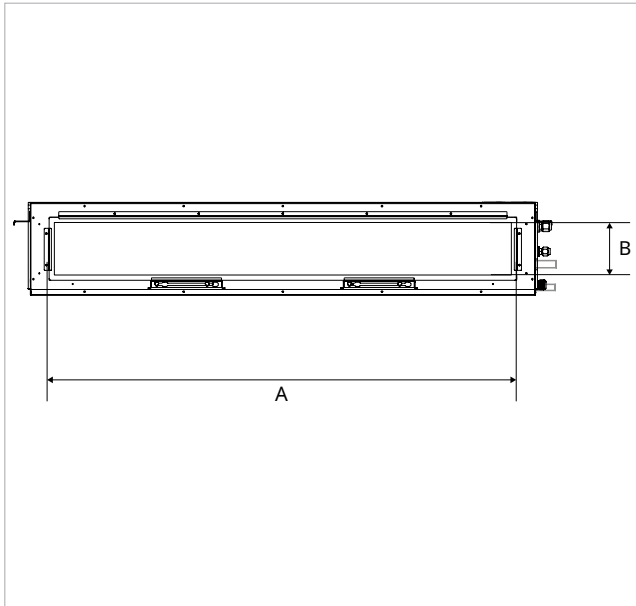

Air supply dimensions

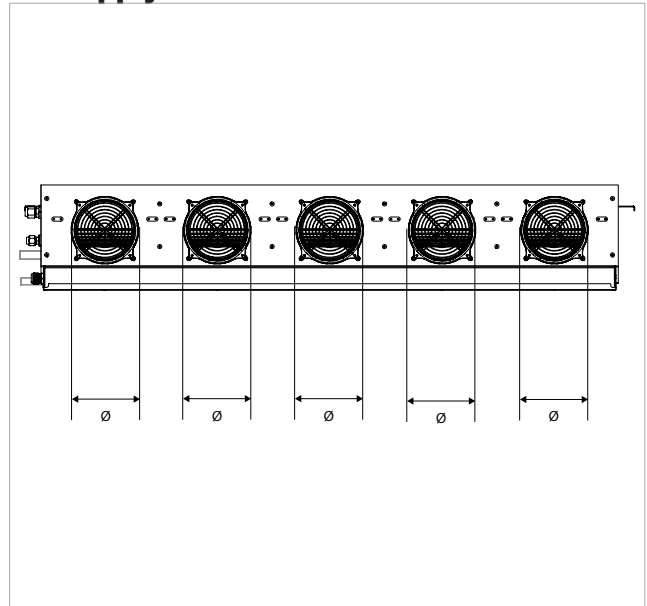

Models	u.m.	4 zones	5 zones
Extract air dimensions			
A	mm	1.020	1.305
B	mm	150	150
Air supply dimensions			
No. of connections		4	5
Supply air connection Ø	mm	160	160

4.14 Electrical connections

The appliance leaves the factory fully wired and only requires connection to the power supply, control and any accessories.

Preliminary warnings

- ⚠ All operations of an electrical nature must be carried out by suitably qualified personnel having the necessary legal knowledge and informed about the risks related to such operations.
- ⚠ All connections must be made in accordance with the relevant regulations in force in the country of installation.
- ⚠ Before carrying out any work, make sure that the power supply is switched off.
- ⚠ The unit should only be powered after the refrigerant, plumbing, and electrical work has been completed.
- ⚠ References:
 - for electrical connections please refer to the wiring diagrams in this manual, especially for the part concerning the power terminal board
- ⚠ Check that:
 - the main supply characteristics are adequate for the power consumption of the appliance, also taking into account any other machinery in parallel operation
 - the power supply voltage and frequency correspond to those specified on the nameplate of the appliance
 - the cables are suitable for installation in accordance with the IEC standards in force
 - the power supply is adequately protected against overloads and/or short circuits
 - the disconnection device is positioned in an easily accessible place to enable intervention in the event of an emergency
- ⚠ It is mandatory:
 - to connect the appliance to an effective grounding system
 - for units with three-phase power supply, check the correct phase connection
 - provide an all-pole switch with a contact opening distance of at least 3 mm that allows complete disconnection under overvoltage category III conditions
 - Install a ground fault circuit interrupter (GFCI). Failure to install this device could result in electric shock
- ⚠ Ensure that a connection to earth is made. Do not ground the appliance to distribution pipes, surge arresters or the ground of telephony systems. If not performed correctly, grounding can cause an electric shock. Momentary high voltage surges caused by lightning or other causes could damage the heat pump.
- ⚠ Use a dedicated power supply circuit. Never use a power supply to which another appliance is also connected due to risk of overheating, electric shock or fire.
- ⚠ For the electrical connection, use a cable of sufficient length to cover the entire distance without any connection. Do not use extension cables. Do not apply other loads on the power supply.
- ⚠ After connecting the interconnection and power supply cables, ensure that the cables are arranged so that they

do not exert excessive forces on the covers or electrical panels. Install the covers on the cables. Incomplete connections of the covers can lead to overheating of the terminals, electric shock or fire.

- ⚠ Any replacement of the power cable must only be carried out by qualified personnel and in accordance with current national regulations.
- ⚠ The Manufacturer is not liable for any damage caused by the lack of earthing or failure to comply with the specifications in the respective diagrams.
- ⚠ The appliance is equipped with a noise filter as required by current regulations. Use selective residual current circuit breakers to compensate for the micro leakage to earth of this device.
- ⊖ Using gas and water pipes to ground the appliance is prohibited.

Power line dimensioning

Use the tables below for the sizing of the power supply line and its protection device.

These are not average draw or transient peaks, but values to be considered for the correct sizing of the plant and the request of the contractual power (excluding loads due to the normal operation of the building).

- ⚠ Maximum power is reached only in exceptional cases. Therefore, the indicated trip current is suggested to guarantee a balance between machine absorption and incidence in the general system.
- ⚠ The indicated minimum cable cross-section area must be verified according to the actual conditions of the installation: length of the cable, characteristics of the electrical supply, etc.

Access to the electrical panel

- ⚠ Access to the electrical panel is only permitted to qualified personnel.
- ⚠ Before carrying out any work, ensure that the power supply is switched off.

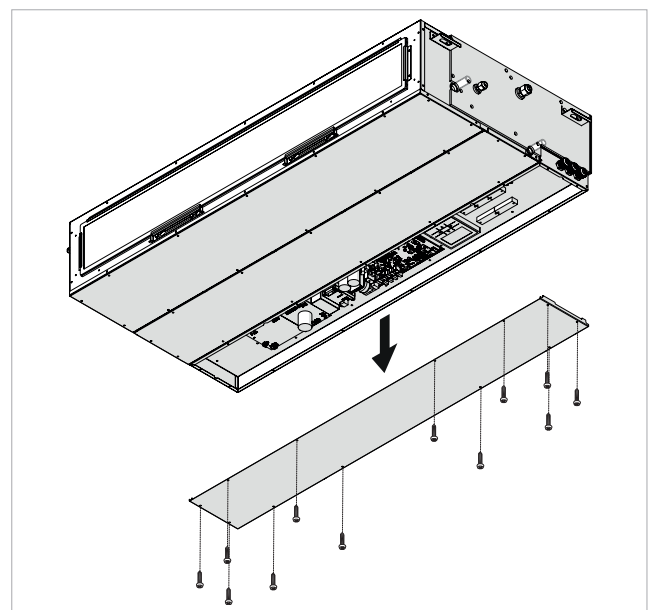

To access the connections:

- ▶ Remove the fixing screws

- ▶ Remove the electrical panel closing panel

Connections

Before connecting the unit to the mains power supply, make sure that the isolator is open. The power supply of the single-phase unit must be connected to the appropriate terminals, subjected to the action of the isolating switch.

- ⚠ Use properly sized cables to avoid voltage drops or overheating.

Connection diagram

- 1. 230/1/50 power supply
- 2. Isolator
- 3. Power cable
- 4. Outdoor unit

- 5. Remote control
- 6. Wired controller communication cable
- 7. Unit
- 8. Commissioning controller (install inside unit or externally)

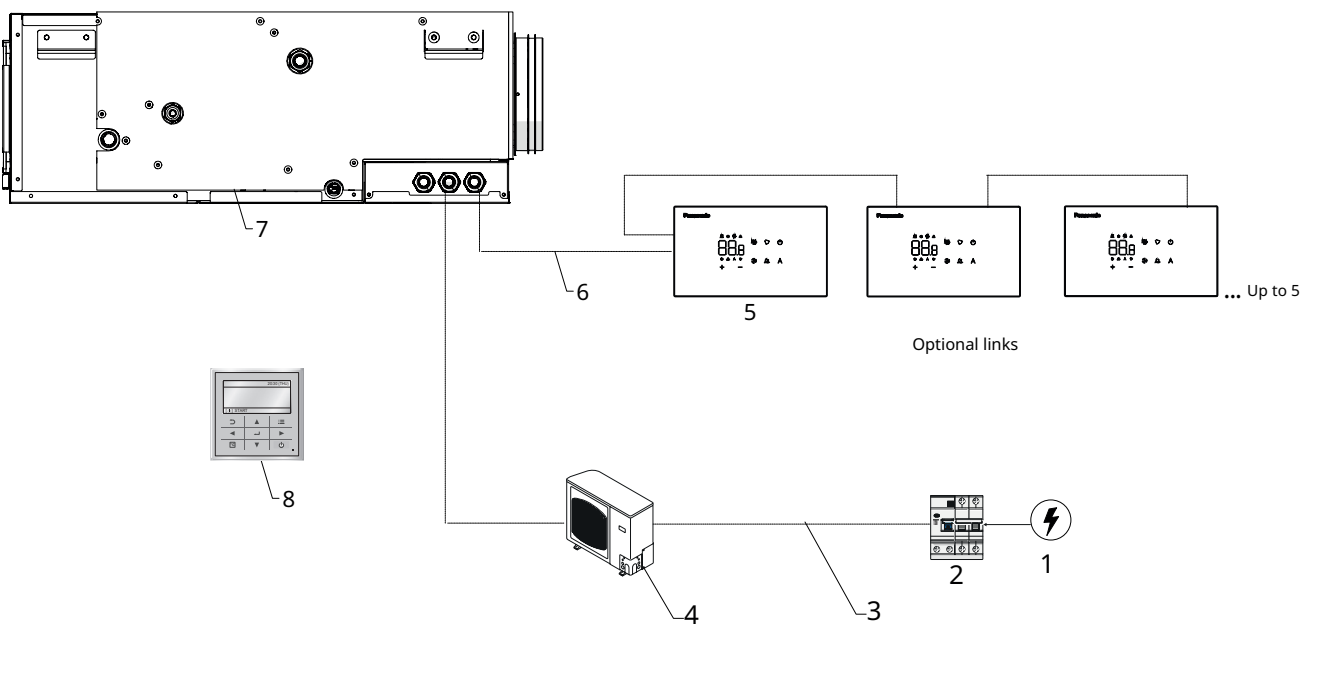

On-board electrical panel

Connection terminal board

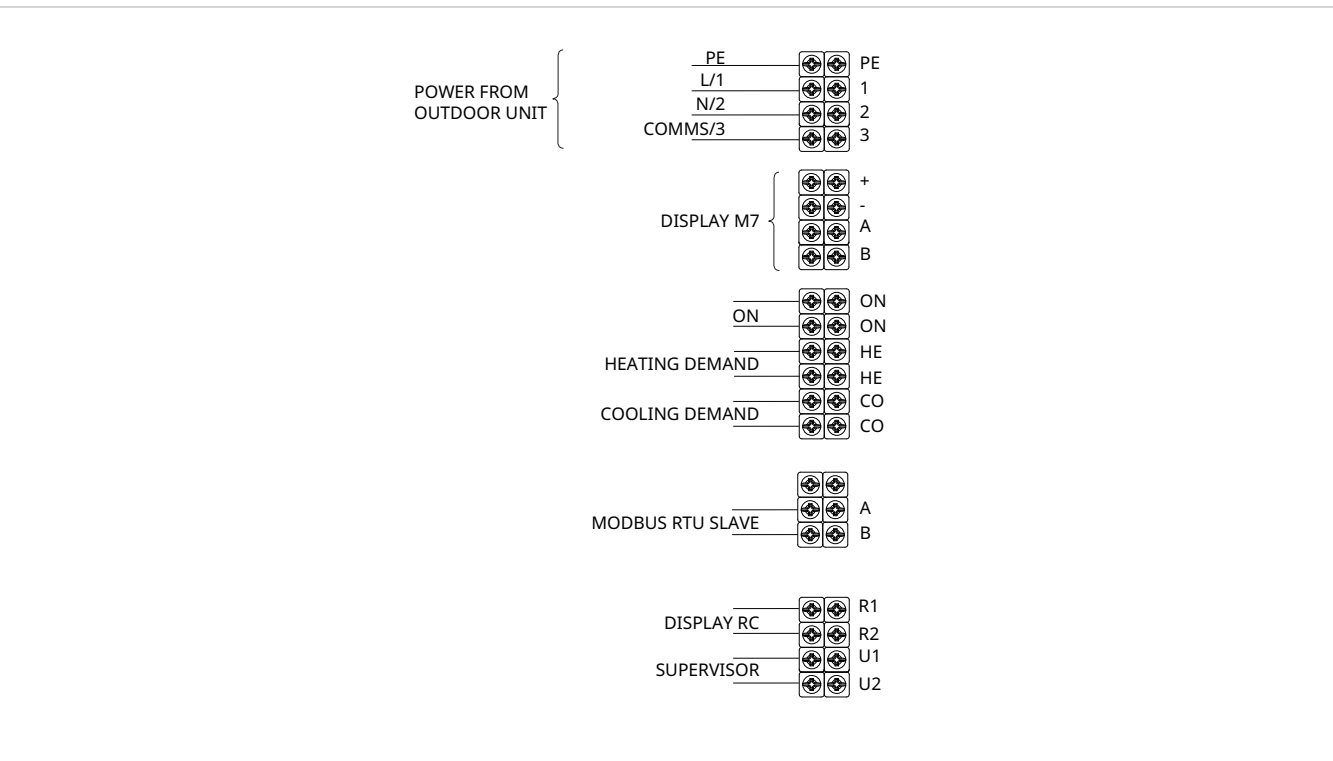

Optional connections

Remote ON/OFF

The remote ON/OFF connection allows switching the unit on and off via an external contact. Connect a switch to the terminals marked ON/ON. When the contacts are open, the unit turns off. When the contacts are closed, the unit turns on.

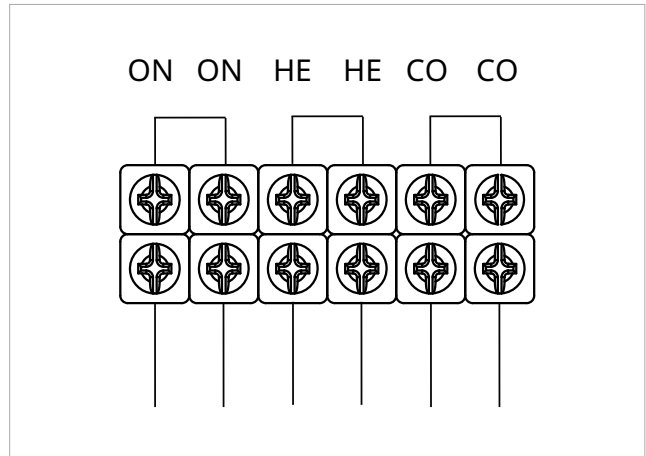
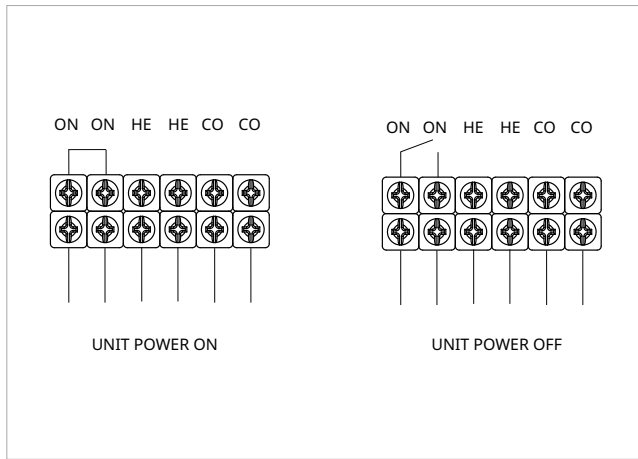

⚠ Remote ON/OFF connection cannot be used

Modbus RTU SLAVE

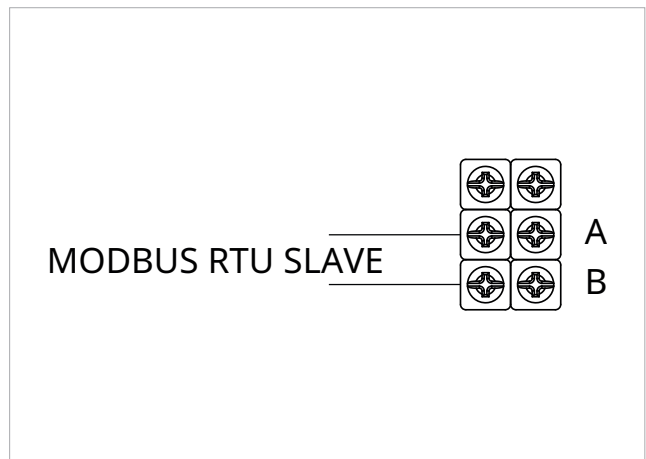

Season selection

WINTER: HEATING

The connection allows remote selection of winter mode (heating). Close the contact between terminals HE and HE. The system selects winter mode.

⚠ The contact between terminals CO and CO must be open.

SUMMER: COOLING

The connection allows remote selection of summer mode (cooling). Close the contact between terminals CO and CO. The system selects summer mode.

⚠ The contact between terminals HE and HE must be open.

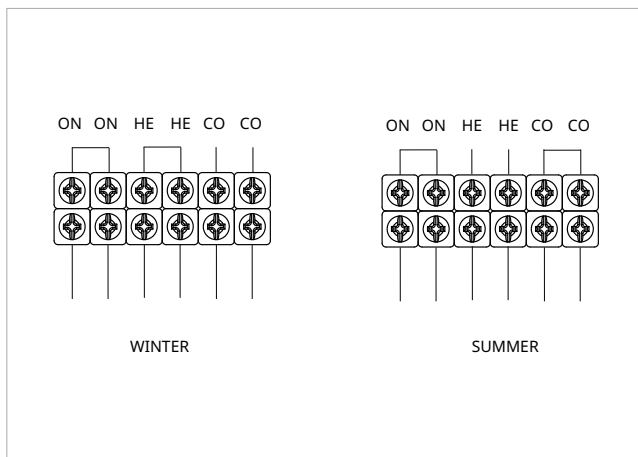

Data is transferred using the MODBUS protocol defined in these specifications exclusively in an environment defined as a master/slave system.

The ordered data progression is defined by the master. A slave is required to respond to its command prompt. For this reason, it is important to ensure that no slave address is assigned more than once during system construction.

It is recommended to preferably use a twisted pair cable with RS485 standard. Only RTU transmission mode is supported; ASCII transmission mode is not supported!

RTU communication settings:

- Rate: 9600
- Start bits: 1
- Number of data bits: 8
- Parity: none
- Stop bits: 1 bit

Season control with M7 thermostat

The connection allows season management directly from the M7 thermostat. Close the contacts between terminals ON, HE and CO. The system enables season selection via the M7 thermostat display.

5. WALL MOUNTED CONTROL EEB749

5.1 Interface

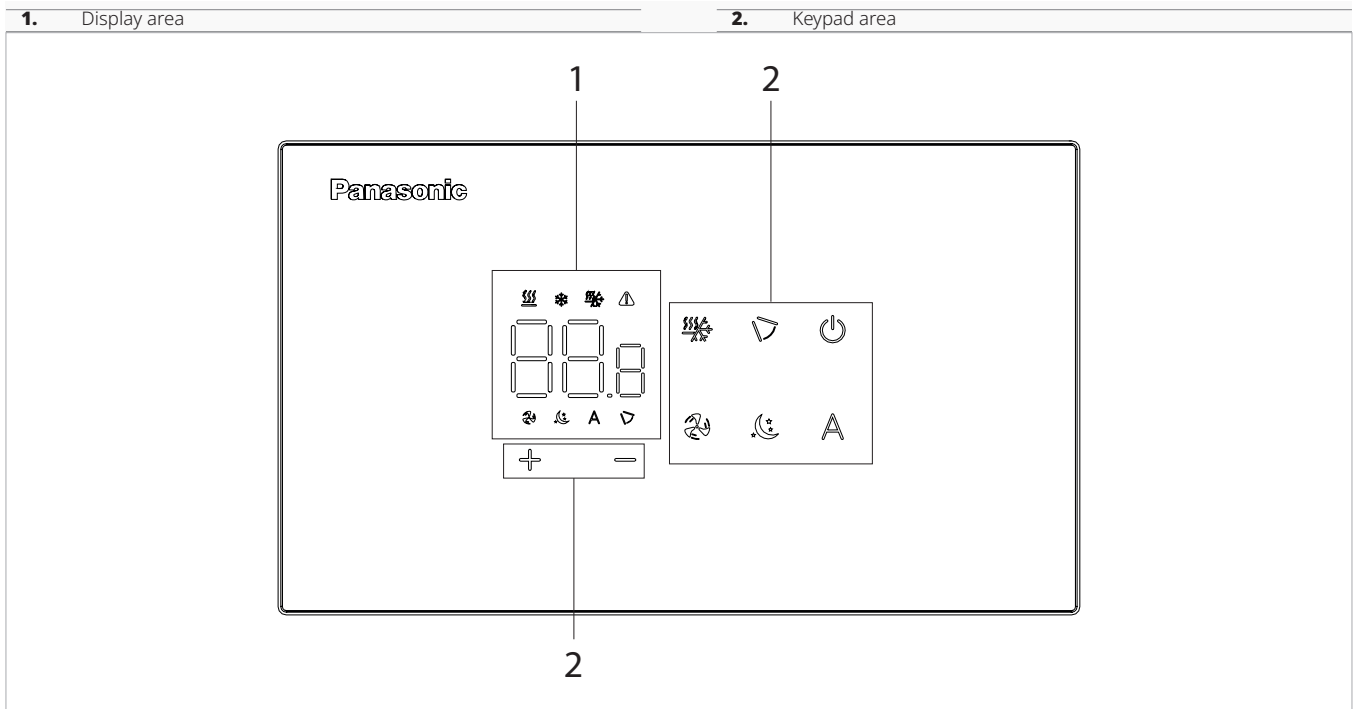

5.2 Installation

Description

The wall remote control is an electronic LED thermostat with a touch interface, capable of controlling multiple devices equipped with the same electronic board. It is equipped with a temperature and humidity sensor.

⚠ The command can control up to 16 devices.

Mounting

⚠ The control panel for wall control must be installed inside an electrical back box (503 type or 2 gang box with 121 mm fixing hole centres)

⚠ Before proceeding with the installation of the wall control panel, it is necessary to prepare the wall for housing the back box, unless providing surface mounted back box arrangement

⚠ Make sure that:

- the wall supports the weight of the appliance
- the section of wall does not contain pipes or electrical lines
- the functionality of load-bearing elements is not compromised

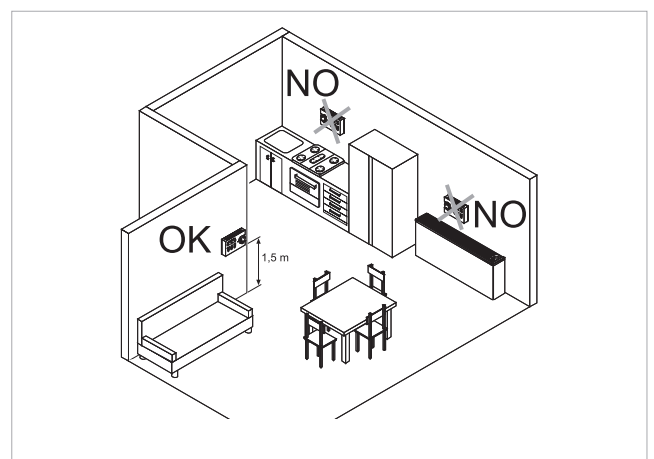

The wall control must be installed:

- on the outside walls
- at a height of approx. 1.5 m above the floor
- ⚠ If the control is located in an area used by people with reduced physical capabilities, refer to local regulations.
- away from doors and windows

- away from heat sources such as radiators, fan coils, cookers, direct sunlight

⚠ The wall control is supplied already assembled in the package.

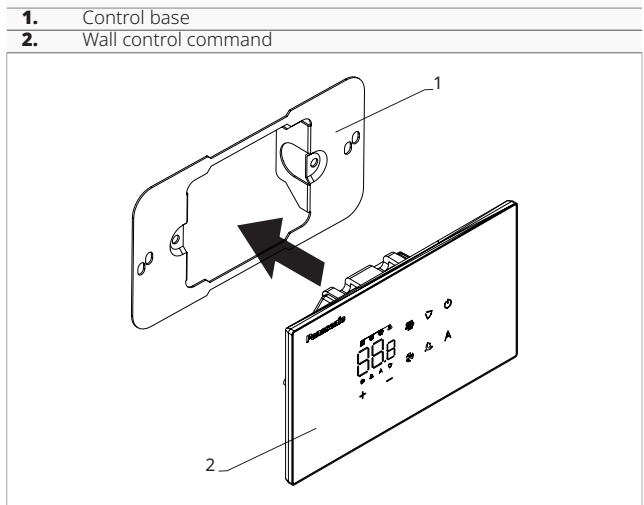

Before mounting on the wall:

- ▶ Separate the control base from the control panel

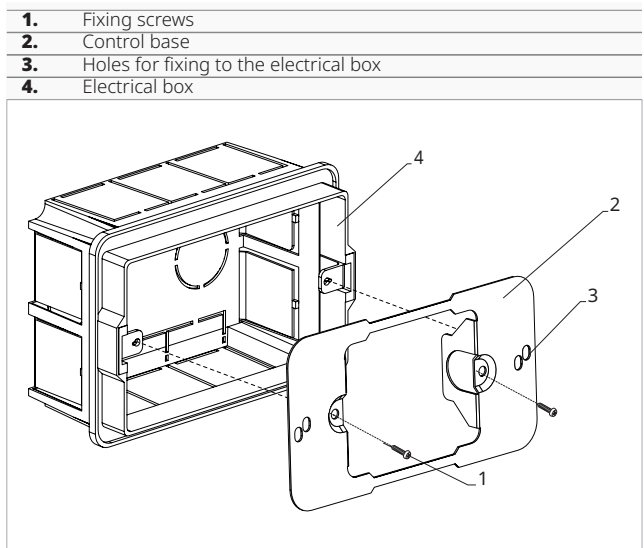

For wall mounting of the control panel:

- ▶ Fix the control base to the electrical back box with screws
- ▶ Make the connections

⚠ It is mandatory to use ferrules on all conductors, both on the board side and on the flush-mounted terminal block side, in order to prevent permanent damage to the equipment.

To avoid incorrect temperature measurement:

- ▶ Seal the cable entry points to prevent air from passing through
- ▶ Seal all openings present in the box or the wall
- ⚠ Proper sealing ensures the correct functioning of the sensor and the reliability of the temperature control.
- ⚠ Before making the connections, check that the terminal block of the command is on the right side.

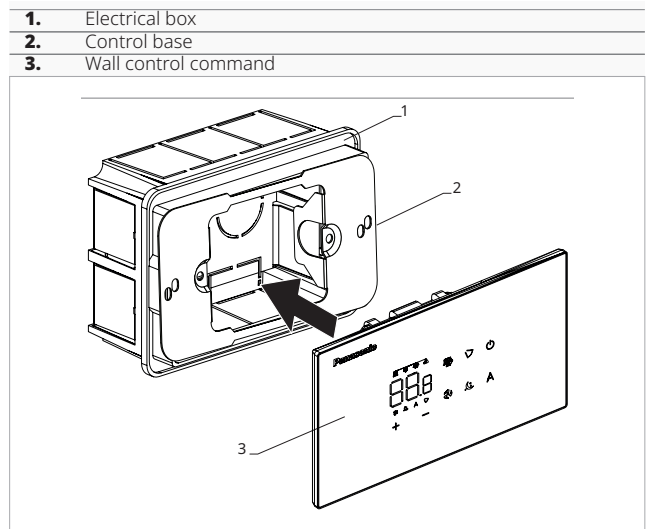

- ▶ reposition the control panel onto the base
- ⚠ Be careful not to crush the wires when closing the control.

5.3 Connection diagram

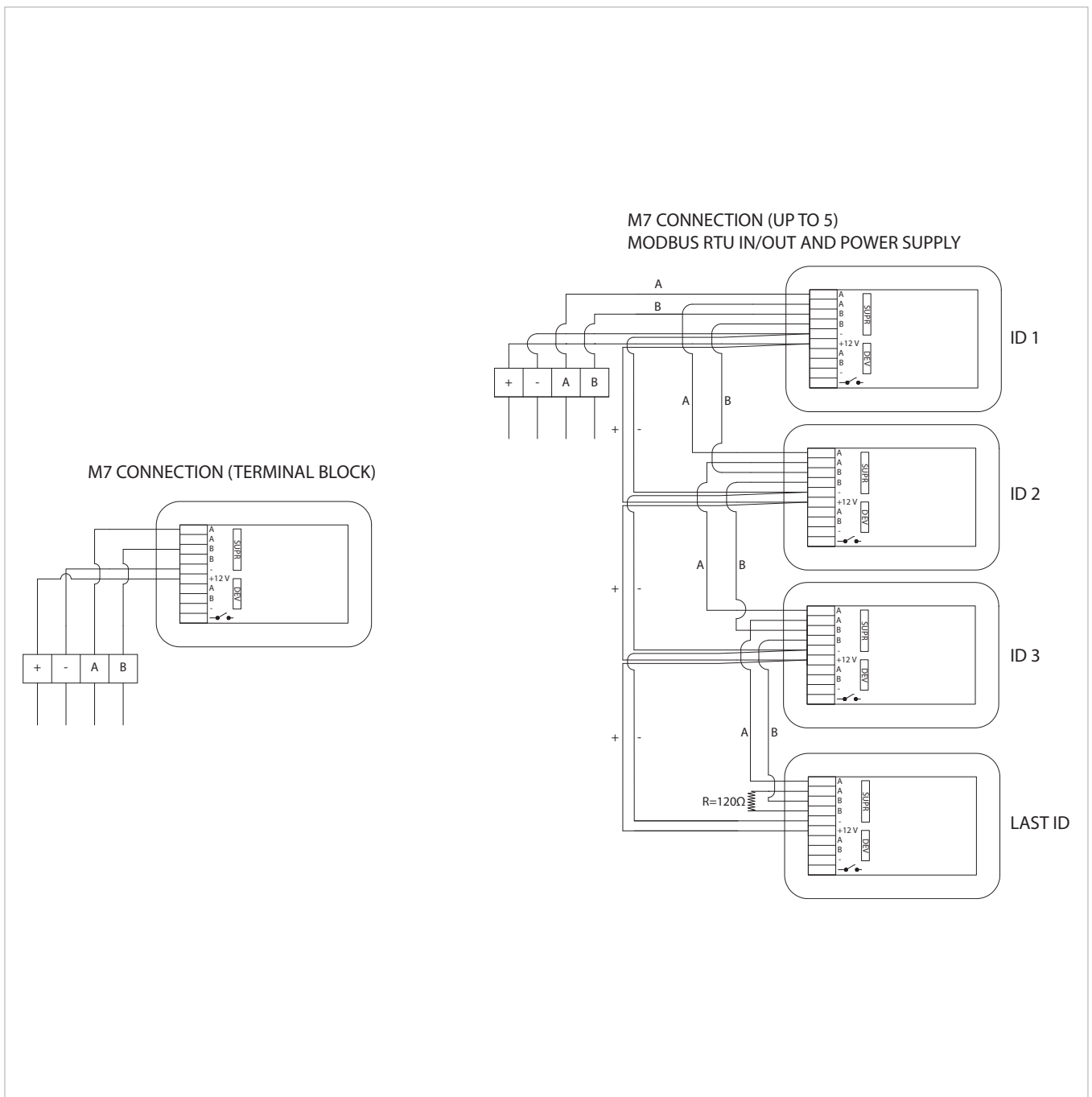

- ⚠ The configuration of 1 to 5 displays is set via DIP switches and M7 settings
- ⚠ The A and B connection is mandatory in daisy chain mode, with termination resistor on the last device
- ⚠ The + and - connection can be in daisy chain or parallel mode
- ⚠ For A and B, use a shielded cable suitable for serial communication
- ⚠ Refer to table "Pairing between control and device" p. 42

5.4 Connections

Preliminary warnings

- ⚠ The terminals for connecting the control panel and the CP presence contact are inserted in a plastic bag and placed on the inside of the electrical box cover.
- ⚠ It is mandatory to use ferrules on all conductors, both on the board side and on the flush-mounted terminal block side, in order to prevent permanent damage to the equipment.

The terminals accept:

- rigid or flexible cables with a cross-section from 0.2 to 1 mm²
- rigid or flexible cables with a cross-section of 0.5 mm² if connecting two conductors in the same terminal
- rigid or flexible cables with a maximum cross-section of 0.75 mm² if equipped with a plastic collar ferrule

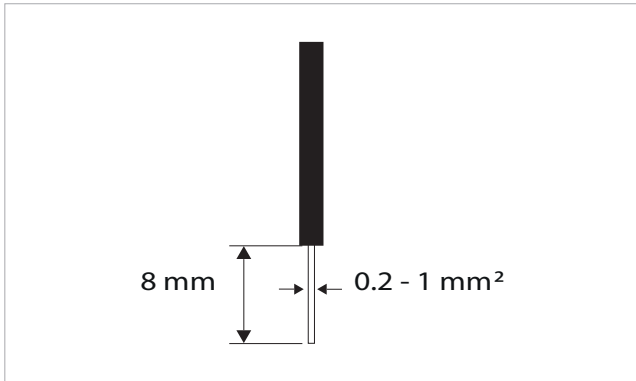

To connect the cables:

- ▶ Strip 8 mm
- ▶ In the case of a rigid cable, insert it easily
- ▶ in the case of a flexible cable, use needle-nose pliers to assist
- ▶ Push the cables in completely
- ▶ Verify correct attachment by pulling them slightly

Remote control

- ⚠ The wall control panel must be ordered separately.

Position of the terminal blocks:

1. Terminal block (Panel rear view)

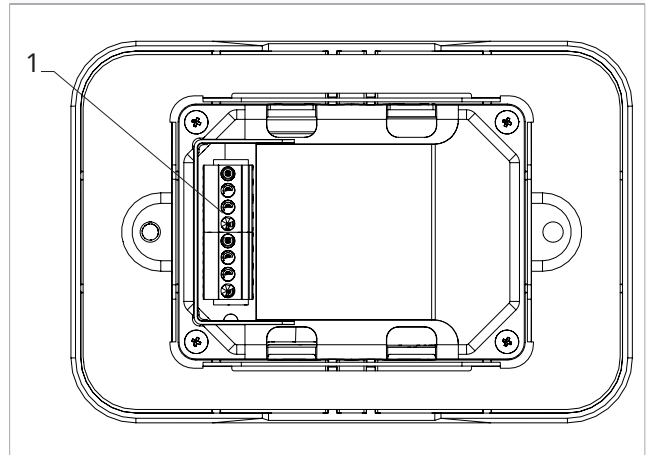

CP presence contact

Through this contact it is possible to connect an external device which inhibits the operation of the appliance, such as:

- window open contact
- remote on/off
- presence infrared sensor
- enabling badge
- remote season change

Operation

The contact is normally open.

- ▶ When the CP contact, connected to a clean, non-live contact, is closed, the device goes into stand-by

The symbol  is displayed on the screen

- ▶ When a button is pressed on the display, the symbol  appears

- ⊖ It is forbidden to connect the CP input in parallel with other electronic boards. Use separate contacts.

The CP presence contact can be configured for heating and cooling operation via the (digital input) setting menu.

RS485 serial connection

The wall remote control can be connected via an RS485 line to one or more devices, up to a maximum of 16.

The devices must be equipped with an electronic board suitable for remote control.

For the connection

- ▶ Follow the connection diagram
- ▶ Connect following the A and B indications

For pairing

- ▶ Refer to chapter "Pairing between control and device" p. 42

- ⚠ Use a suitable shielded bipolar cable for RS485 serial connection with a minimum cross-section of 0.35 mm².
- ⚠ Keep the two-core cable separate from the power supply cables.





⚠ Route in such a way as to minimise the length of deviations.

⚠ Terminate the line with a 120 Ω resistor.
 Ⓣ Star connections are prohibited.



5.5 Functions

Basic menu

To access the basic menu

- ▶ From display off, hold the button  for 10 seconds
The device turns on and  appears
- ▶ Hold until the indication  appears
- ▶ Release the button 
The symbol  appears

To navigate within the menu

- ▶ Use the icons  

To select menu items and confirm changes

- ▶ Press the icon 
Confirming the change moves to the next item.

To exit the menu

- ▶ Press the icon  for 10 seconds
- ▶ Or wait 30 seconds for automatic shutdown

⚠ After a period of 30 seconds from the last action, the display turns off and the changes made are automatically saved.

Menu items

ot: Offset AIR probe (air probe adjustment)

ur: Value read from the humidity sensor

ut: Offset RH probe

uS: Humidity setpoint

uI: Humidity hysteresis

CF: Scale





ub: Buzzer volume

uu: Not used

uP: Not used

Set AIR sensor offset





To set the air sensor adjustment

- ▶ Select 
- ▶ Press  to change settings
- ▶ Increase or decrease the value with the icons  
- ▶ Press  to confirm
*By default, it is set to 0.
 The setting range is from a minimum of -12.0 °C to a maximum of 12.0 °C.*

Set RH sensor offset





⚠ Only change after finding actual deviations compared to a real measurement made with professional equipment.

To set the RH sensor adjustment

- ▶ Select 
- ▶ Press  to change settings
- ▶ Increase or decrease the value with the icons  
- ▶ Press  to confirm





Set humidity setpoint

To set the humidity setpoint

- ▶ Select 
- ▶ Press  to change settings
- ▶ Increase or decrease the value with the icons  
- ▶ Press  to confirm
The setting range varies from 20.0% to 90.0%.



Set humidity hysteresis

To set the humidity hysteresis

- ▶ Select 
- ▶ Press  to change settings
- ▶ Increase or decrease the value with the icons  
- ▶ Press  to confirm
The setting range is from a minimum of 1 to a maximum of 30.





Scale

To change the temperature unit

- ▶ Select 
- ▶ Press  to change settings
- ▶ Select °C or °F
- ▶ Press  to confirm
By default, the temperature unit is °C.

Adjust volume

To change the control volume

- ▶ Select 
- ▶ Press  to change settings
- ▶ Increase or decrease the value with the icons  
- ▶ Press  to confirm
By default, the volume is set to 5.

⚠ The volume changes after confirming the modification.

Advanced menu

⚠ To access the advanced menu, you must first access the basic menu. See paragraph "Basic menu" p. 41.

Through the control panel you can access the advanced menu.

To access the advanced menu

- ▶ From the basic menu press **A**
□□ appears
- ▶ Press the **+** button once
□ | appears
- ▶ Press **⏻** to confirm and access
The advanced menu is accessed.

To navigate within the menu

- ▶ Use the icons **+** **←**

To select menu items and confirm changes

- ▶ press **⏻** for 2 seconds
Confirming the change moves to the next item.

To exit the menu

- ▶ Press **⏻** for about 10 seconds
□ | appears
- ▶ Press **⏻** for about 10 seconds
The display turns off.
- ▶ Or wait 30 seconds from the last action
The display turns off automatically.

⚠ After a period of 30 seconds from the last action, the display turns off.

Menu items

Ad: Not used

Pr: Not used

di: Options for the digital input

UC: Not used

Ac: Not used

Ah: Not used

Fr: Not used

Select the digital input**To change the digital input**

- ▶ Select □ |
- ▶ Press **⏻** to change settings
- ▶ Select CP for presence contact (default)
- ▶ Select CO for cooling open
- ▶ Select CC for cooling close
- ▶ Press **⏻** to confirm
By default, the digital input is set to CP.

⚠ To return to the default settings, set the digital input to "CP".

⚠ By selecting one of the other inputs (CO, CC), the seasonality is locked and can no longer be changed using the **⏻** button on the control.

Pairing between control and device

⚠ The matching procedure between control and luminaire is mandatory in case of a connection between several luminaires.

To correctly set the ID for an M7 display:

- ▶ With the display on, hold **⏻** for about 10 seconds
- ▶ Wait for access to the base menu (00)
- ▶ Press the A button to change menu
- ▶ wait for code 00 to appear on the left of the display
- ▶ Press the + button
- ▶ wait for code 01 to appear on the display
- ▶ Press once **⏻**
- ▶ You access menu 01
- ▶ search for parameter Ad using the **+** or **←** keys
- ▶ Press **⏻** to access the parameter
- ▶ Check the displayed value (default 00, or assigned ID)

With one switch ON, the corresponding zone and the next one are controlled, with the thermostat ID = number of the first switch

With multiple consecutive ON switches, the zones following the first switch are controlled, with thermostat ID = previous ID +1

With non-consecutive ON switches, the zones corresponding to each switch are controlled, with the first thermostat ID = number of the first switch and the second thermostat ID = previous ID +1

⚠ It is not possible to control consecutive zones

DIP-SW FNC DX combinations Model 7110

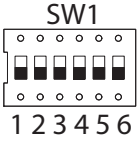
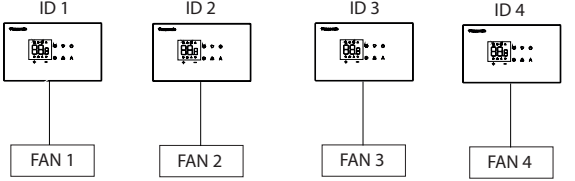
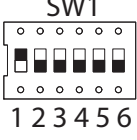
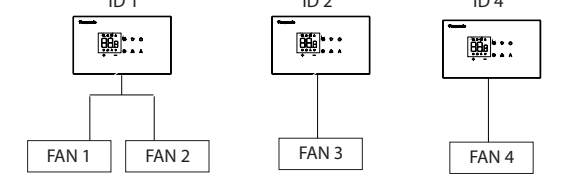
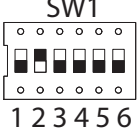
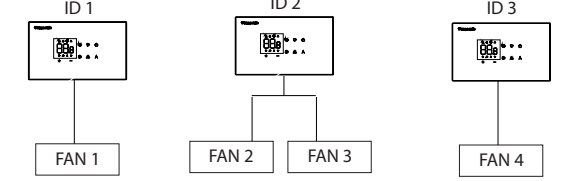
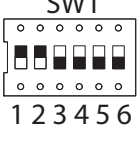
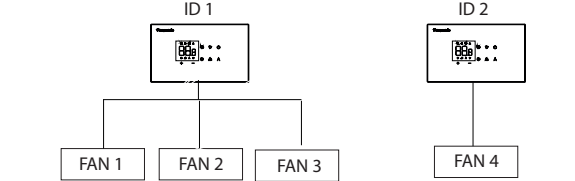
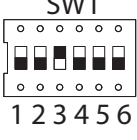
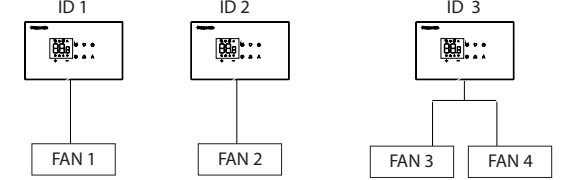
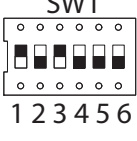
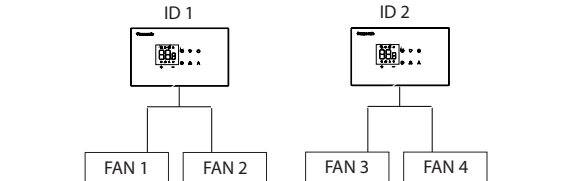
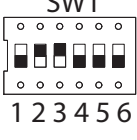
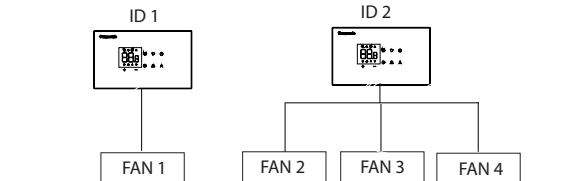
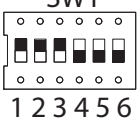
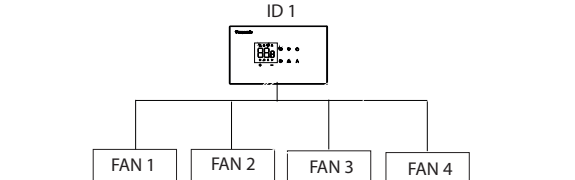
 <p>SW1 ON 1 2 3 4 5 6</p>	<p>EVERYONE OFF</p>	
 <p>SW1 ON 1 2 3 4 5 6</p>	<p>SWITCH 1 ON</p>	
 <p>SW1 ON 1 2 3 4 5 6</p>	<p>SWITCH 2 ON</p>	
 <p>SW1 ON 1 2 3 4 5 6</p>	<p>SWITCH 1, 2 ON</p>	
 <p>SW1 ON 1 2 3 4 5 6</p>	<p>SWITCH 3 ON</p>	
 <p>SW1 ON 1 2 3 4 5 6</p>	<p>SWITCH 1, 3 ON</p>	
 <p>SW1 ON 1 2 3 4 5 6</p>	<p>SWITCH 2,3 ON</p>	
 <p>SW1 ON 1 2 3 4 5 6</p>	<p>SWITCH 1, 2, 3 ON</p>	

⚠ Switch 4, 5, 6 always OFF

DIP-SW FNC DX combinations Model 1014

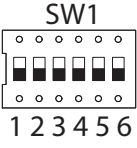
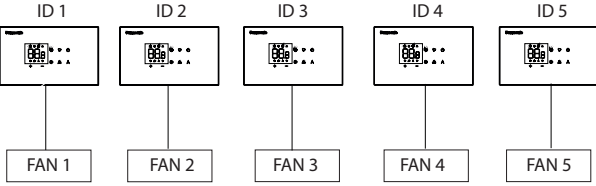
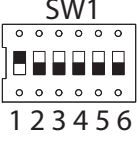
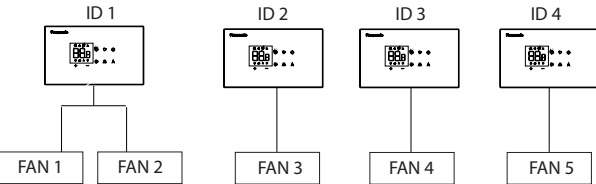
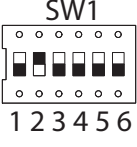
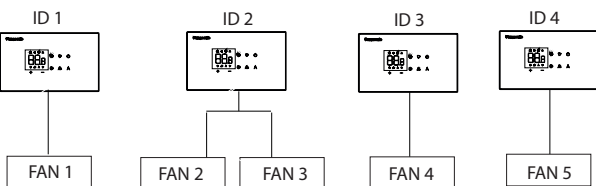
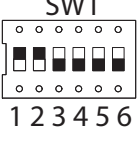
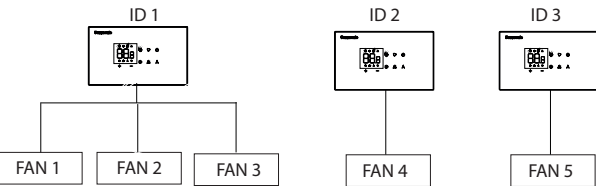
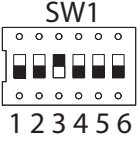
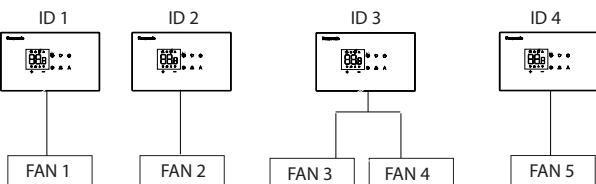
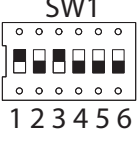
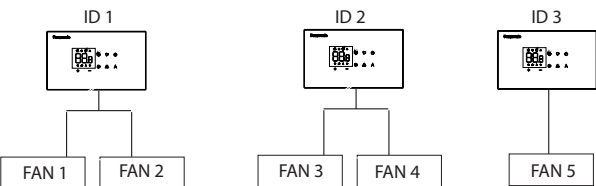
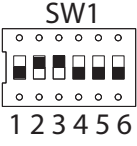
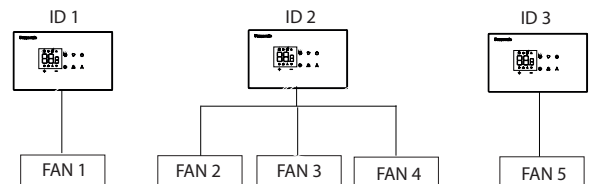
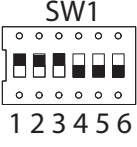
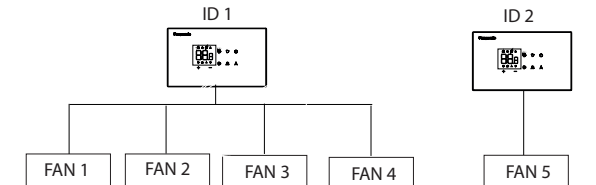
 <p>SW1 ON 1 2 3 4 5 6</p>	<p>EVERYONE OFF</p>	
 <p>SW1 ON 1 2 3 4 5 6</p>	<p>SWITCH 1 ON</p>	
 <p>SW1 ON 1 2 3 4 5 6</p>	<p>SWITCH 2 ON</p>	
 <p>SW1 ON 1 2 3 4 5 6</p>	<p>SWITCH 1, 2 ON</p>	
 <p>SW1 ON 1 2 3 4 5 6</p>	<p>SWITCH 3 ON</p>	
 <p>SW1 ON 1 2 3 4 5 6</p>	<p>SWITCH 1, 3 ON</p>	
 <p>SW1 ON 1 2 3 4 5 6</p>	<p>SWITCH 2, 3 ON</p>	
 <p>SW1 ON 1 2 3 4 5 6</p>	<p>FROM SWITCH 1, 3 ON</p>	

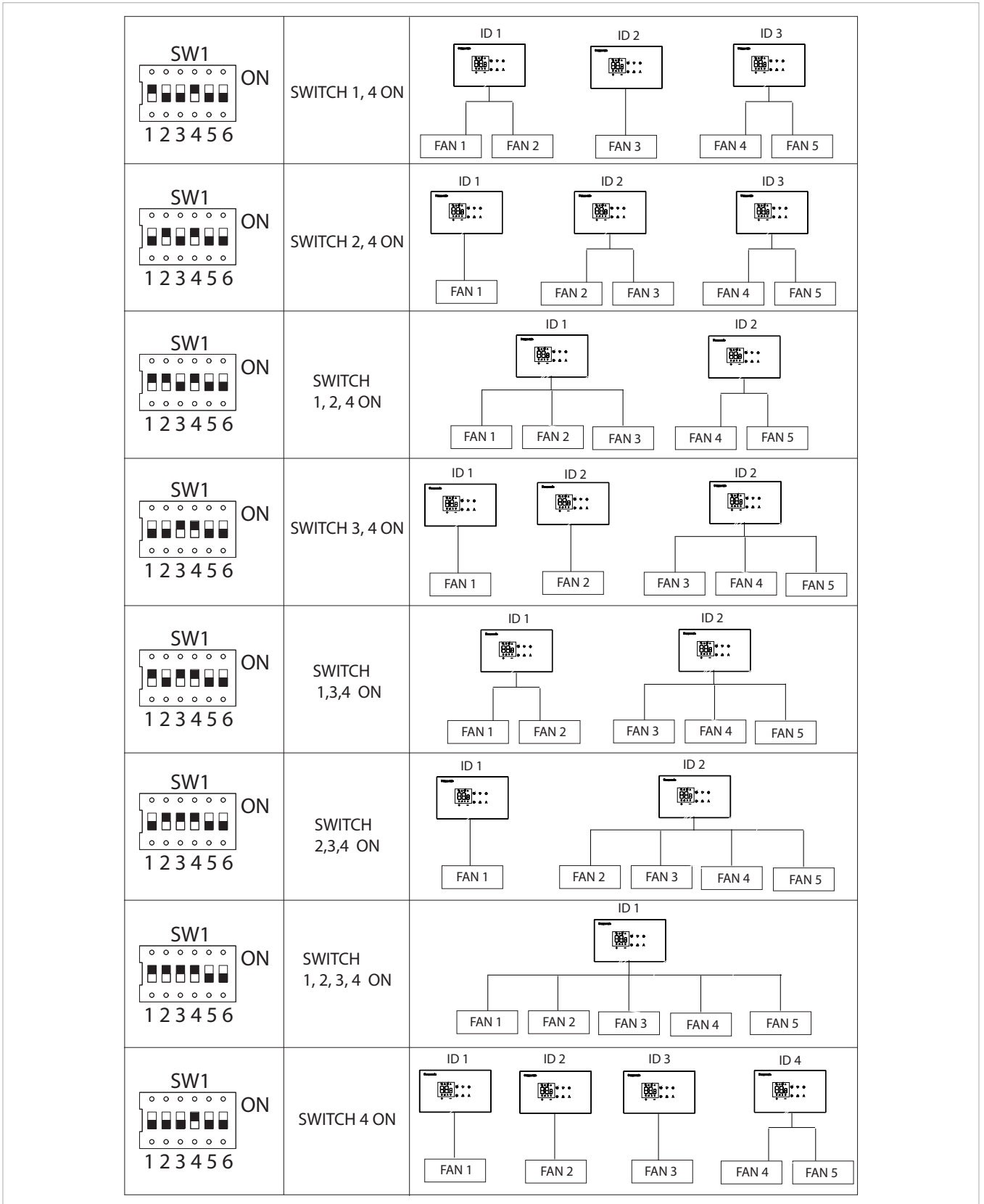





⚠ Switch 5, 6 always OFF

Display alarms on the wall control panel

- ⚠ In case of an alarm, the appliance still maintains some active functions.
- ⚠ To indicate alarms on the control panel for wall control, the fixed symbol  is displayed.
- ⚠ **To access the settings menu, you first need to access the basic menu. See paragraph "Basic menu" p. 41.**



To view errors on the wall control panel

- ▶ Access the basic menu
- ▶ Press  *appears*
- ▶ Press 
- ▶ Press  *appears*
- ▶ press  to access the menu
Subsequently, the number assigned to the fan coil appears and then the error is displayed.

Displayed alarms

Alarms displayed	Description
A0X	Communication error with fan number X
A1X	Fan number X is faulty or does not follow the target value correctly
A2X	Communication error with M7 number X
A30	Internal coil sensor failure
A31	Intake air sensor failure
A32	Outlet air sensor failure

How to set fan speed

- ▶ with the display on, press and hold  for about 10 seconds
- ▶ Wait for access to the base menu (00)
- ▶ Press the A button to change menu
- ▶ select menu 10
by scrolling through the menu, r1, r2, r3, r4, r5, r6 are available
when accessed, the preset fan speeds are displayed
- ▶ press  or  to change the speed
once the various speeds have been set, they will correspond to the set values L1, L2, L3, L4, night and AUTO
this applies to the zones under the M7 I modified
if the M7 controls one zone, only the fan speed of that zone will be modified
whereas if the M7 controls multiple zones, all the fans in those zones will follow the newly set speed



Refer to the table below for the correspondence between speeds r1, r2, r3, r4, r5, r6 and levels L1, L2, L3, L4, night and AUTO.

Correspondence LEVEL - RPM SETTING					
R1	Min L1 - Min night				Min auto
R2	Max L1 - Max night	Min L2			
R3		Max L2	Min L3		
R4			Max L3	Min L4	
R5				Max L4	Max auto

Fan speed is modulated between the minimum and maximum of each level, according to the difference between the temperature

To set Ed on an M7 display

To correctly set Ed on an M7 display:

- ▶ With the display on, hold  for about 10 seconds
- ▶ Wait for access to the base menu (00)
- ▶ Press the A button to change menu
- ▶ wait for code 00 to appear on the left of the display
- ▶ Press the + button
- ▶ wait for code 01 to appear on the display
- ▶ Press once 
- ▶ You access menu 01
- ▶ search for the Ed item to set remote mode
- ▶ press  to access
- ▶ set to Yes

Setting the static pressure of the appliance

The appliance is supplied with a default static pressure of 50 Pa (LOW); it is possible to select 3 other static pressures (HIGH, MED, SUPER LOW), depending on the speeds r1, r2, r3, r4 and r5 set according to the following table:

TABLE PRESSURE SETTING / LEVEL / RPM				
	HIGH (150pa)	MED (100pa)	LOW (DE-FAULT 50pa)	SUPER LOW (0pa)
Pa	150	100	50	0
R1 (rpm set)	1250	1050	850	650
R2 (rpm set)	1450	1250	1050	850
R3 (rpm set)	1650	1450	1250	1050
R4 (rpm set)	2000	1650	1450	1250
R5 (rpm set)	2400	2000	1650	1450

- ⚠ To view the graph, refer to chapter "Pressure/ventilation curves" p. 71

6. START-UP

6.1 Preliminary warnings

⚠ **This section is dedicated to the Authorised Service Centre. The specifications of the Authorised Service Centre are described in chapter "[Ref]" .**

⚠ **Initial commissioning must be carried out by the Authorised Service Centre.**

⚠ **For detailed information on accessories, please refer to the relevant instruction sheets.**

See chapter "[Ref]"

⚠ The customer must be present during the appliance operation test and informed about the contents of the manual and the procedures. Once commissioning is completed, the manual must be handed over to the customer.

⚠ Before start-up, all works (electrical, hydraulic and air-flow connections) must have been completed.

Preliminary warnings for R32

⚠ The unit uses R32 refrigerant, with a Global Warming Potential (GWP) of 675. Do not release R32 gas into the atmosphere.

⚠ The R32 refrigerant gas is mildly flammable and odourless.

⚠ All precautions regarding the handling of refrigerant must be followed in accordance with current regulations.

⚠ Avoid proximity to continuously operating ignition sources (open flames, gas appliances, electric stoves, lit cigarettes, etc.).

⊖ It is prohibited to use means to speed up the defrosting process or for cleaning other than those recommended.

⊖ Smoking is prohibited near the appliance.

⊖ The use of mobile phones is prohibited near the appliance.

⊖ It is forbidden to introduce objects and substances through the openings provided for the intake and delivery of air.

⚠ Perform the following checks:

- Perform safety checks to ensure that the risk of combustion is minimised
- avoid working in confined spaces
- delimit the area around the workspace
- ensure safe working conditions around the area by checking for flammable materials

Leak detection

⊖ Using combustion-based refrigerant fluid detectors, such as a halide torch or any other system using an open flame, is prohibited.

⚠ For leak detection, follow the following instructions:

- use electronic detectors to search for flammable refrigerant fluids
- before usage, ensure the detectors are properly calibrated
- calibration operations must be carried out in an area free from refrigerant fluid
- ensure the detector is not a potential ignition source and is suitable for the refrigerant fluid used
- if a leak is suspected, all open flames must be eliminated
- in the event of a leak requiring brazing, it is mandatory to recover all refrigerant fluid from the system or isolate it (using shut-off valves) in a part of the system away from the leak
- ⚠ The use of silicone sealant can compromise the effectiveness of certain types of leak detection instruments.

6.2 First start-up

Preliminary Checks

Before commissioning, check that:

Operational checks

- all safety conditions have been met
- the unit has been properly secured to the supporting surface or wall
- the minimum technical spaces have been observed

Electrical checks

- the cross-section of the power supply cables is adequate for the absorption of the appliance and the length of the connection made

- grounding is correctly performed
- the electrical connections have been established correctly
- all electrical connections are properly secured and all terminals are adequately tightened
- the voltage is within a tolerance of 10% compared to the unit's nominal voltage
- the power supply for the three-phase models has a maximum phase imbalance of 3%
- all control wires are connected and that all electrical connections are secure

Refrigerators

- the refrigerant connections have been made following the instructions provided in the manual
- the shut-off valves of the refrigeration circuit are open

Powering up

⚠ **Before starting, power up the unit for at least 12 hours.**

⚠ Make sure that the control panel is switched off.

To power up the unit:

- ▶ Set the main switch to ON

The display will light up a few seconds after powering up. Check that the operating status is OFF.

⚠ **For performing operations, refer to the Control Panel Manual.**

Start-up

After all checks have been carried out, the unit can be put into operation.

To activate the appliance:

Check that you have correctly performed "Pairing between control and device" *p. 42* for unit addressing.

To select multiple fans for a single zone

Check that you have correctly selected the "DIP-SW FNC DX combinations Model 7110" *p. 43*, depending on how many fans are used per single zone.

Appliance static pressure setting:

Check that you have selected the desired static pressure via "Setting the static pressure of the appliance" *p. 46*.

Checks with the machine switched on

After starting up, check that

Operational checks:

- verify the different modes of operation
- verify that the appliance stops and then restarts
- switch the appliance off and on again and check that it restarts correctly
- the appliance operates within the recommended operating conditions (see technical specifications table)
- check that the air flow rates are correct

Hydraulic Checks

- check for proper condensate drainage

Electrical Checks

- the current absorbed is less than the maximum indicated in the technical data table
- the supply voltage value is within the set limits and does not fall below the nominal value -10 % during operation

6.3 Plant delivery

Once all the checks and controls on the correct operation of the plant have been completed, the installer must explain the following to the user:

- the basic functional characteristics of the appliance
- the instructions for use
- the routine maintenance

6.4 Switching off for extended periods

If the appliance is not used for a long period of time, the following steps must be taken:

- ▶ Deactivating the device
- ▶ Isolate the power supply
- ⚠ To restart the appliance after it has been out of use for a long period, call in the Authorised Service Centre.

7. CONTROL CONFIGURATIONS

7.1 Automatic addressing procedure

Single unit system

1.	Outdoor unit
2.	Connection cable between outdoor unit and indoor unit
3.	Remote controller
4.	Remote control wiring
5.	Indoor unit

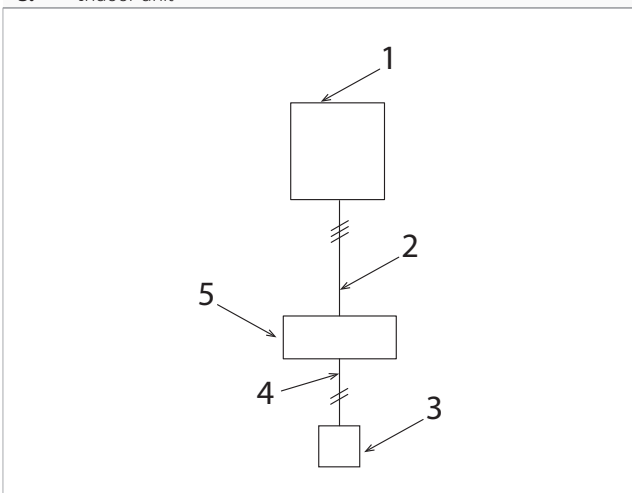

- Check that the combination of external and indoor unit is correct.
- Ensure that all wiring and refrigerant connections have been carried out correctly and that the refrigerant shut-off valves are open before addressing.
- **⚠** Never switch on the external unit before installation is completed.
- Switch on the unit for at least 12 hours before switching it on.
- Switch on the external and indoor units. Automatic addressing should start automatically when the system is switched on.
- Completion of the automatic addressing will take about 10 minutes.
- After completing the automatic addressing setup, wait about 2 minutes, then start the test run.

7.2 Automatic address setting via remote controller

Procedure for CZ-RTC6 controller

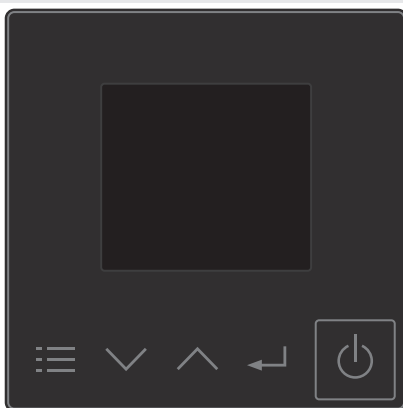

- ▶ Press the ,  and  buttons simultaneously for at least 4 seconds.

The "Maintenance func" screen is displayed on the LCD display

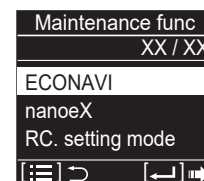

- ▶ Press the or button to display each menu
- ▶ Select "Auto address"

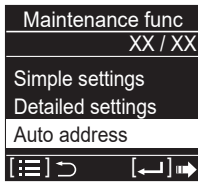

- ▶ Press the button
The "Auto address" screen appears on the LCD display

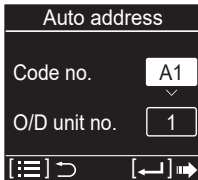

- ▶ Press the or button
- ▶ Select "Code no" to "A1"
After selecting "Code no."
At this point two alternatives are possible by pressing the button or the button

Alternative 1

- ▶ Press the button
- ▶ Press the or button
- ▶ Select one of the "O/D unit no." for automatic addressing

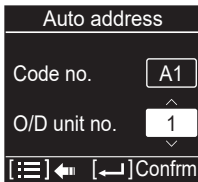

- ▶ Press the button
The addressing procedure starts (duration approx. 10 minutes)

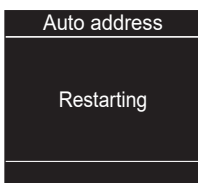

At the end of the procedure the unit returns to stop status.

Alternative 2

- ▶ Press the button
- ▶ The "Auto address" screen appears on the display
- ▶ Press the or button
- ▶ Select "YES"



- ▶ Press the button

Procedure for CZ-RTC5B controller

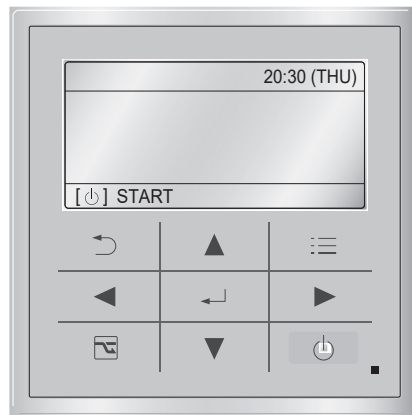

- ▶ Press the , and buttons simultaneously for at least 4 seconds.
- ▶ The "Maintenance func" screen is displayed on the LCD display

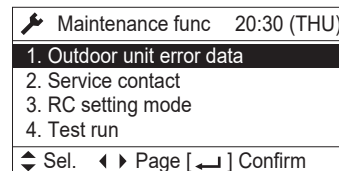

- ▶ Press the or button to display each menu
- ▶ Press the or button to display the next screen immediately
- ▶ Select "9 Auto address"

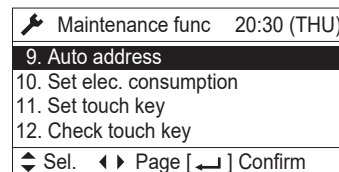

- ▶ Press the button
The "Auto address" screen appears on the display
- ▶ Press the or button

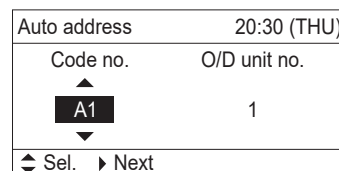

- ▶ Change "Code no." to "A1"
 - ▶ Press the ◀ or ▶ button
 - ▶ Select "O/D unit no."
 - ▶ Press the ▼ or ▲ button
 - ▶ Select "O/D unit no."
 - ▶ Press ↵
- The addressing procedure starts (duration approx. 10 minutes)

At the end of the procedure the unit returns to stop status.

7.3 How to check detailed setting 11

The detailed settings below may need to be checked in the event of a capacity setting error, or if system, local and group addressing must be adjusted manually if automatic addressing is not completed correctly.

The relevant detailed setting codes are as follows:

Code no.	Item
11	Indoor unit capacity

Capacity setting

⚠ Refer to the table below to confirm the capacity code for the respective models. An incorrect capacity setting will result in an error (error codes E15, E16 or L09).

Code no.	4-Zone Model	
	7.1 kW	10.0 kW
11	0012	0015

Code no.	5-Zone Model		
	10 kW	12.5 kW	14.0 kW
11	0015	0027	0018

7.4 How to adjust detailed settings using the remote controller

Procedure for CZ-RTC6 controller

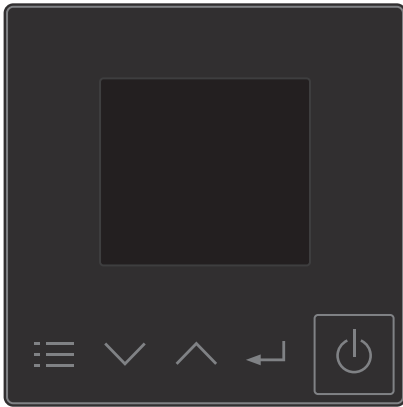

- ▶ Press the , and buttons simultaneously for at least 4 seconds.
The "Maintenance func" screen is displayed on the LCD display

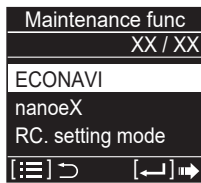

- ▶ Press the or button to display each menu
- ▶ Select "Detailed settings" on the LCD display

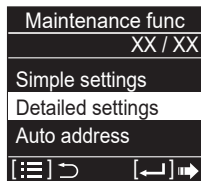

- ▶ Press the button
- ▶ Press the or button to select "Unit no."
- ▶ Press the button

⚠ If the address setting is not correct, "ALL" will be displayed in the "Unit n." field.

At this point two alternatives are possible by pressing the button or the button

Alternative 1

- ▶ Press and hold the button for 2 seconds while selecting "Code no."



Change the "Code no." one digit at a time so that it becomes [0000XX] by following the procedures below:

- ▶ Press the or button to change the value
After changing the value

- ▶ Press the or button and set the next digit

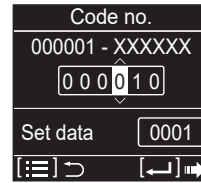

FIGURE A

After changing the value

- ▶ Press the button and set the next digit
- ▶ Press the or button to change the value

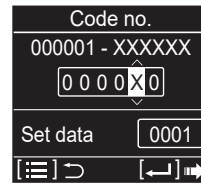

FIGURE B

After changing the value

- ▶ Press the button and set the next digit
- ▶ Press the or button to change the value

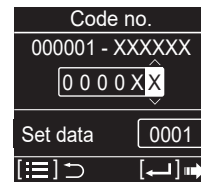
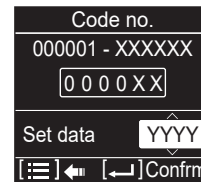

FIGURE C

After changing the value

- ▶ Press the button
- ▶ Press the or button to select one of the setting data "YYYY"



- ▶ Select "Set data"
- ▶ Press the button

If you want to make a continuous setting, follow the procedures in Fig. A.

If you want to change the selected indoor unit or finish the setting, follow the next step:

- ▶ Press the button twice
The display returns to the initial step

Alternative 2

- ▶ Press the button
The "Detailed setting-end screen" is displayed

- ▶ Press the or button
- ▶ Select "YES"

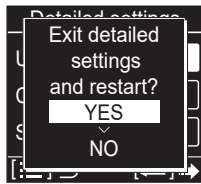

- ▶ Press the button
Return to the normal remote controller display

Procedure for CZ-RTC5B controller

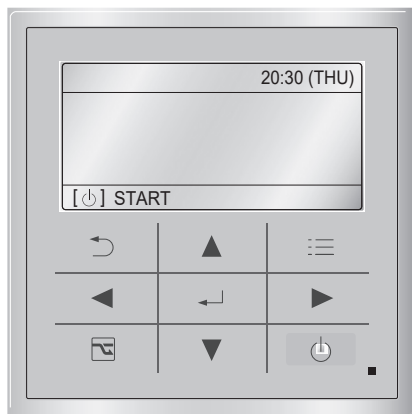

Press the , , and buttons simultaneously for at least 4 seconds.

- ▶ Display "Maintenance func" on the LCD display.

Maintenance func	20:30 (THU)
1. Outdoor unit error data	
2. Service contact	
3. RC setting mode	
4. Test run	
◆ Sel. ◀ ▶ Page [↵] Confirm	

- ▶ Press the or button to display each menu
- ▶ Press or to display the next screen immediately
- ▶ Select "8. Detailed settings" on the LCD display

Maintenance func	20:30 (THU)
5. Sensor info.	
6. Servicing check	
7. Simple settings	
8. Detailed settings	
◆ Sel. ◀ ▶ Page [↵] Confirm	

- ▶ Press the button
The "Detailed settings" screen is displayed on the LCD display
- ▶ Press the or button to select and change "Unit no."

Detailed settings		20:30 (THU)
Unit no.	Code no.	Set data
1-1	10	0001
◆ Sel.	▶ Next	

⚠ If the address setting is not correct, "ALL" is displayed in the "Unit no." field

- ▶ Press the or button to select "Code no."

Detailed settings		20:30 (THU)
Unit no.	Code no.	Set data
1-1	XX	YYYY
◆ Sel.	▶ Next	

- ▶ Press the or button to change "Code no." to "XX"
- ▶ Press the or button to select "Set data"

Detailed settings		20:30 (THU)
Unit no.	Code no.	Set data
1-1	XX	YYYY
◆ Sel.	[↵] Confirm	

- ▶ Press the or button to select one of the setting data "YYYY"
- ▶ Press the button

If you want to change the selected indoor unit, follow the step below:

- ▶ Press the or button to select "Unit no." and make changes

⚠ If the address setting is not correct, "ALL" is displayed in the "Unit no." field

If you do not want to change any data, proceed as follows:

- ▶ Press the button
The "Exit detailed settings and restart?" screen is displayed on the LCD display (end of detailed settings)
- ▶ Press the or button
- ▶ Select "YES"

Detailed settings		20:30 (THU)
Exit detailed settings and restart?		
YES	▶	NO
◆ Sel.	▶ Next	

- ▶ Press the button
Return to the normal remote controller display

7.5 Test run using the remote controller

Procedure for CZ-RTC6 controller

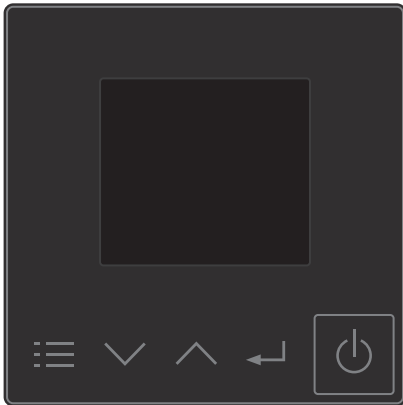

- ▶ Press the , and buttons simultaneously for at least 4 seconds.
The "Maintenance func" screen is displayed on the LCD display

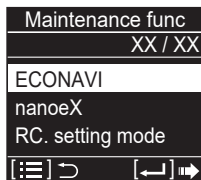

- ▶ Press the or button to display each menu
- ▶ Select "Test Run" on the LCD display

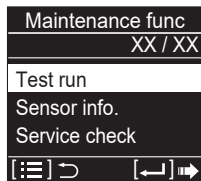

- ▶ Press the button
- ▶ Press the or button to change the display from "OFF" to "ON"

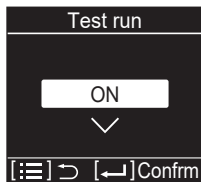

- ▶ Press the button
- ▶ Press the button
"TEST" is displayed on the LCD display

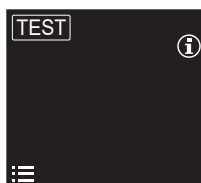

- ▶ Press the button
The test run starts

The test run setting mode screen is displayed on the LCD display.

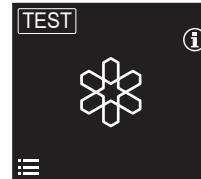

- The test run can be performed in HEATING, COOLING or VENTILATION mode
- Temperature cannot be adjusted in test run mode
- If correct operation is not possible, a code will be displayed on the remote controller LCD display
 - ⚠ To view the alarm content, refer to the "Failures and remedies" section.
 - After completing the test, proceed from the initial step and switch to "OFF" at the next step.
 - ⚠ To prevent the test from being performed continuously, this remote controller includes a timer function that cancels the test after 60 minutes.
 - ⚠ The external units will not operate for about 3 minutes after start-up and stop of operation

Procedure for CZ-RTC5B controller

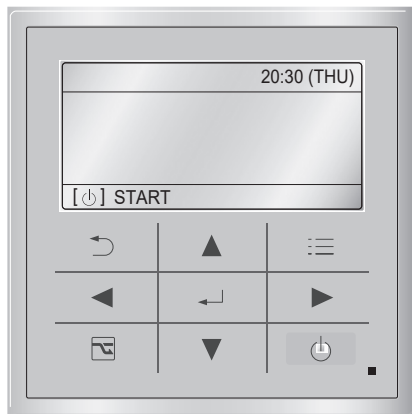

- ▶ Press the , and buttons simultaneously for at least 4 seconds.
- ▶ Display "Maintenance func" on the LCD display.

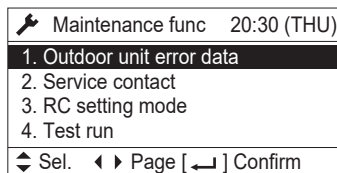

- ▶ Press the or button to display each menu
- ▶ Press or to display the next screen immediately
- ▶ Press the or button
- ▶ Select "4 Test run" on the LCD display

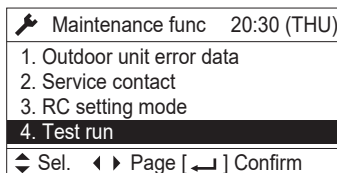

- ▶ Press the or button to change the display from "OFF" to "ON"

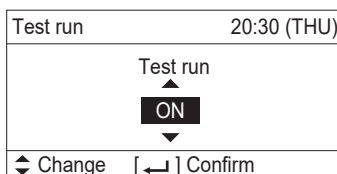

- ▶ Press the button
- ▶ Press the button
"TEST" is displayed on the display

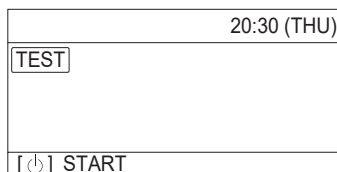

- ▶ Press the button
The test run starts
The test run setting mode screen is displayed on the LCD display.

- The test run can be performed in HEATING, COOLING or VENTILATION mode

- Temperature cannot be adjusted in test run mode
- If correct operation is not possible, a code will be displayed on the remote controller LCD display
- ⚠ To view the alarm content, refer to the "Failures and remedies" section.
After completing the test, proceed from the initial step and switch to "OFF" at the next step.
- ⚠ To prevent the test from being performed continuously, this remote controller includes a timer function that cancels the test after 60 minutes.
- ⚠ The external units will not operate for about 3 minutes after start-up and stop of operation

8. MAINTENANCE

8.1 Routine maintenance

Annual operations

The once-a-year maintenance plan includes the following operations and checks and must be carried out by the Authorised Service Centre or by qualified personnel.

Electrical circuit

Check:

- electrical supply voltage
- the electrical absorption
- tightening connections
- that there is no damage or excessive wear to electrical cables
- that the gaskets and sealing materials have not deteriorated to such an extent that they are no longer suitable for the purpose of preventing the development of flammable atmospheres inside
- the correct fixing of cable glands
- safety devices

Mechanical checks

Check:

- tightening of the screws, fans and electrical box, of the unit's external panelling
 - the state of the structure
- ⚠ Bad fixings result in abnormal noise and vibration.
⚠ If oxidised parts are present, treat them with suitable paints to eliminate or reduce oxidation.

Hydraulic controls

Check:

- the regular drainage of condensate
- cleaning the condensate collection trays
- cleaning the exhaust ducts

Airflow controls

Check:

- the regular flow of air
- cleaning of any intake grilles
- cleaning the ducting

Cleaning

- cleaning or filter replacement
- cleaning the heat exchanger

Cleaning or filter replacement

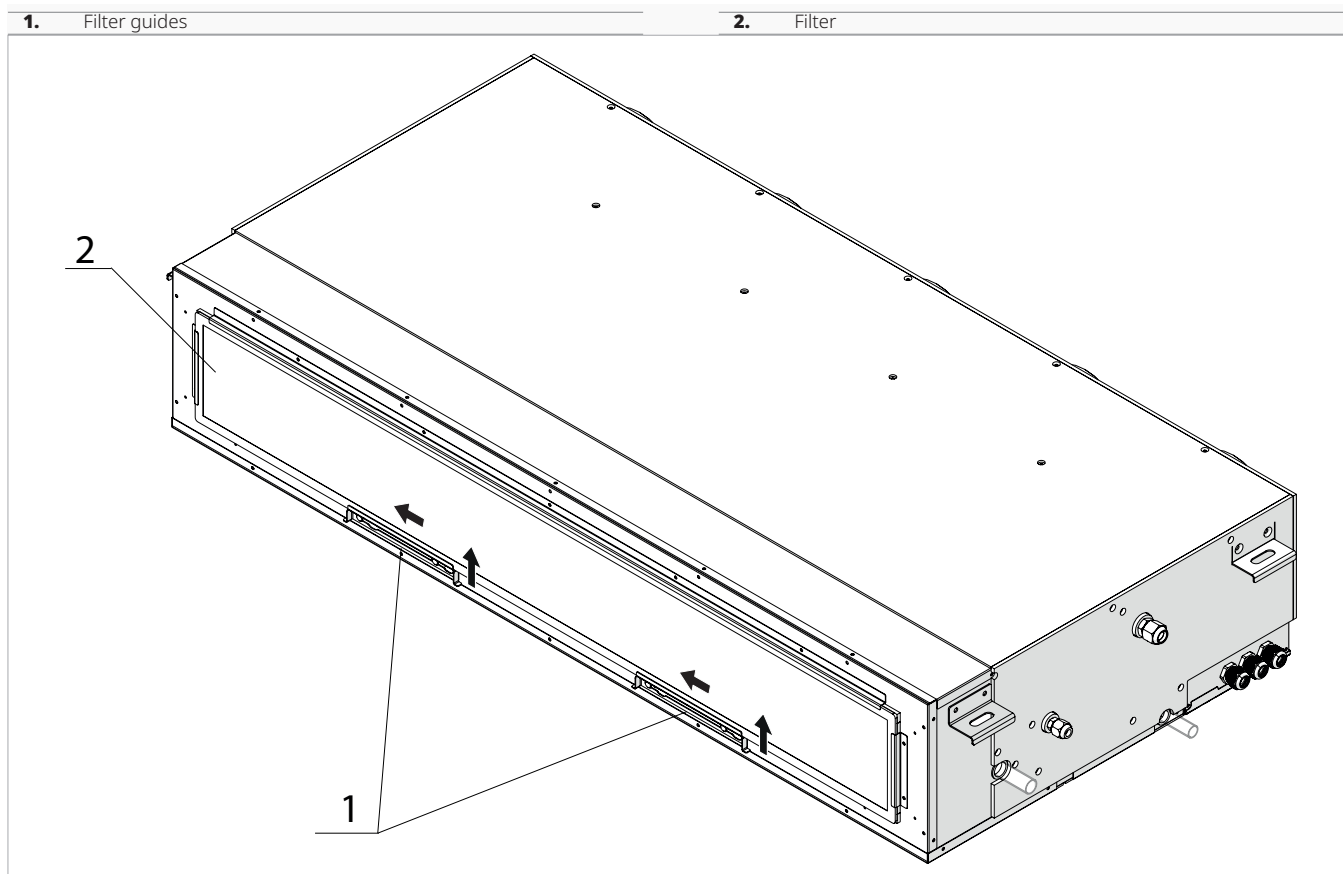

To remove:

- ▶ lift the filter guides upwards and slide them to the left
- ▶ Take out the filter
- ⚠ Pay attention to sharp surfaces
- ⓘ **If the condition of the filters is acceptable, they can be cleaned using a vacuum cleaner or a low-pressure compressor.**
- ⓘ **If it is impossible to clean them, the filters must be replaced.**

To reposition:

- ▶ Perform in reverse order
- ⚠ If the unit is positioned in a way that makes filter removal more difficult, as explained above, follow the procedure below

To remove:

- ▶ unscrew the screws of the filter guides, the side or upper one
- ▶ remove the filter guides
- ▶ Take out the filter

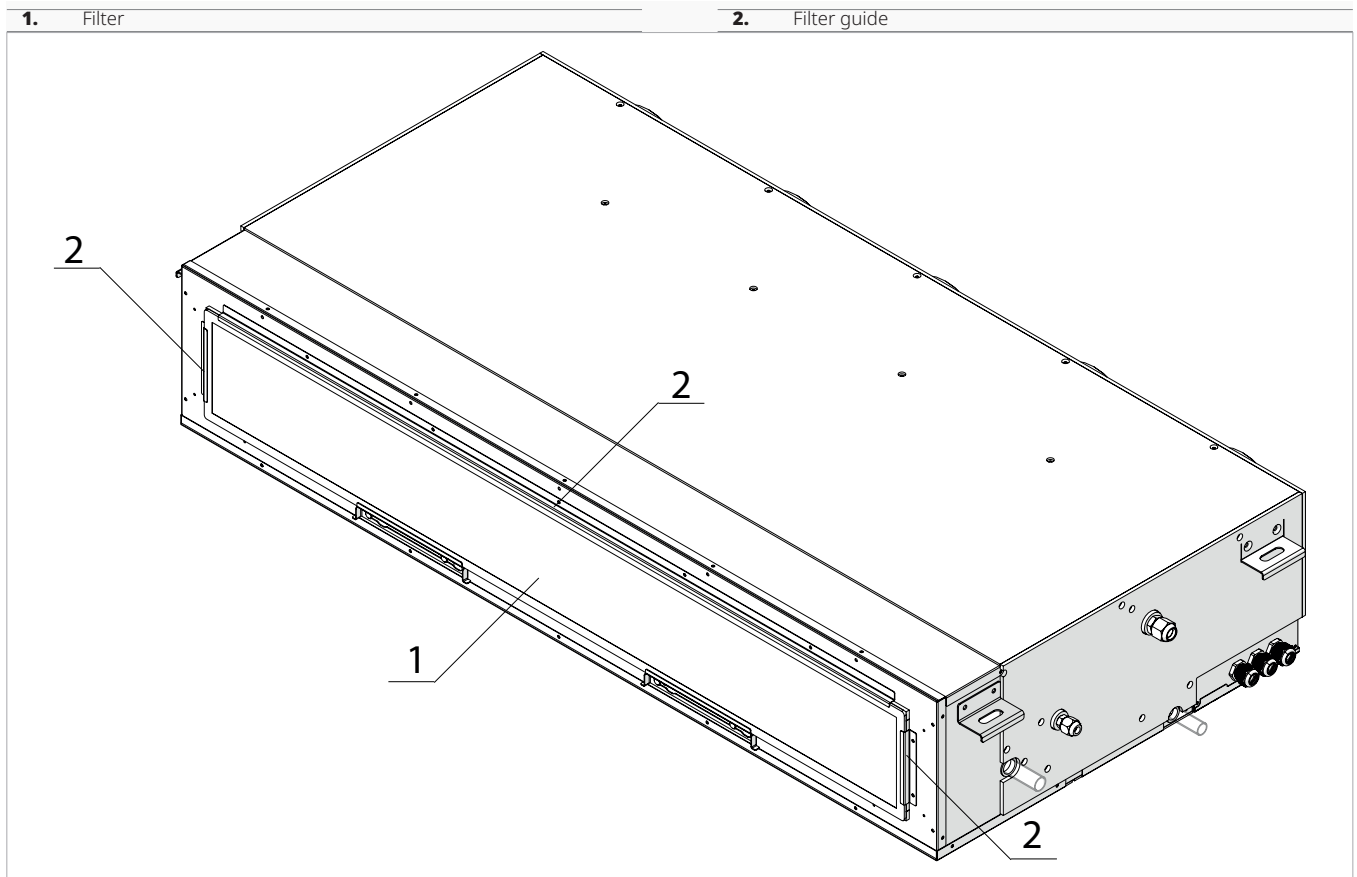

To reposition:

- ▶ Perform in reverse order

Cleaning the heat exchanger

Cleaning the heat exchanger

1. Lower panel
2. Lower panel support

3. Condensate collection tray

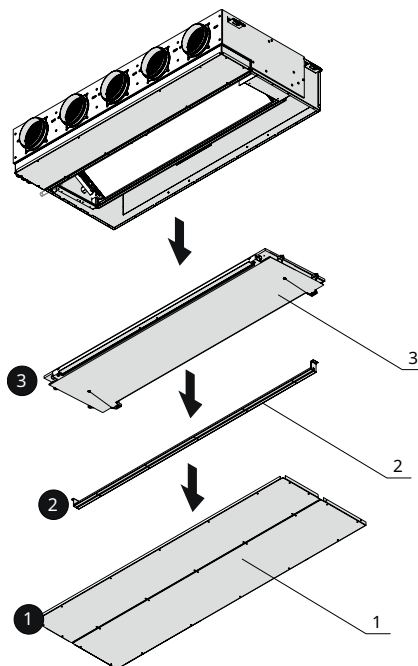

- ▶ Isolate the power supply to the unit
- ▶ Disconnect the condensate drain pipe
- ▶ Access the heat exchanger
- ▶ Gently proceed with the cleaning of the heat exchanger using a vacuum cleaner or a low-pressure compressor

To reposition:

- ▶ Perform in reverse order
- ⚠ Never touch the fins of the heat exchanger.

9. DECOMMISSIONING

9.1 Safety warnings

- ⚠ Before carrying out this procedure, it is essential that the technician has a complete understanding of the equipment and all its details.
- ⚠ It is recommended to safely recover all refrigerants.
- ⚠ Before performing the activity, an oil and refrigerant sample must be taken in case an analysis is required before reusing the recovered refrigerant.
- ⚠ It is essential that the power supply is available before starting the activity.
- ⚠ Become familiar with the equipment and its operation.
- ⚠ Electrically isolate the system.
- ⚠ Before attempting the procedure, make sure that:
 - mechanical handling equipment should be available, if necessary, for the handling of refrigerant cylinders
 - all personal protective equipment is available and used properly
 - the recovery process should be supervised at all times by a competent person
 - the recovery equipment and cylinders comply with the appropriate standards
- ⚠ If possible, evacuate the refrigeration system.
- ⚠ If it is not possible to achieve a vacuum, create a manifold so that the refrigerant can be removed from various parts of the system.
- ⚠ Make sure the cylinder is weighed on the scale before the recovery takes place.
- ⚠ Start the recovery machine and operate it according to the manufacturer's instructions.
- ⚠ Do not overfill the cylinders. No more than 80% of the liquid charge volume.
- ⚠ Do not exceed the maximum working pressure of the cylinder, even temporarily.
- ⚠ When the cylinders have been filled correctly and the process is complete, ensure that the cylinders and equipment are removed from the site in a timely manner and that all isolation valves on the equipment have been closed.
- ⚠ The recovered refrigerant must not be charged into another refrigeration system unless it has been cleaned and checked.

10. FAULTS AND REMEDIES

10.1 Preliminary warnings

If one of the following faults is found:

- the ventilation does not activate even if hot or cold water is present in the hydraulic circuit
- the appliance makes excessive noise
- there is dew formation on the front panel

Follow the instructions below:

- ▶ Immediately isolate the power supply
- ▶ Contact an Authorised Service Centre or professionally qualified personnel
- ⚠ The intervention must be carried out by a qualified installer or an Authorised Service Centre.
- ⊘ Personal intervention is prohibited.

10.2 Troubleshooting table

DESCRIPTION OF FAULT	CAUSE	REMEDY
The fans are not active	The power supply is not switched on	Check the fan power supply
	The fan speed regulation device does not work	Check fan speed regulation device
	Incorrect electrical connections	Check electrical connections.
Insufficient air flow or pressure	Clogged filters	Clean filters
	Insufficient rotation speed	Increase rotation speed
	Ducting or exchanger clogged	Clean ducting or heat exchanger
Insufficient heat exchanger efficiency	Exchanger fins clogged	Clean exchanger surfaces
Excessive vibration and noise	Incorrect installation of the unit	Check unit brackets and fastenings
	Incorrect ducting installation	Check brackets and duct fixings
	Fan impeller imbalance	Check fan impeller condition
Water leaks from unit	Clogged condensate drain	Clean condensate drain
	Siphon not installed correctly	Check the correct installation of the siphon
Difficult start-up	Supply voltage too low	Check that the supply voltage is not below 10% of the rated voltage

10.3 Alarms displayed on the control panel of the external unit

Alarms displayed	Cause	Remedy
P03	Abnormal compressor discharge temperature > or = to 103 °C.	Check the refrigeration cycle (possible excessive refrigerant charge). Verify the opening of the refrigerant valves. Check the compressor discharge temperature probe (TD) and replace if necessary.
P04	High-pressure switch intervention on the external unit.	In the summer cycle, check the free circulation of air around the outdoor unit. Verify the refrigerant charge. In the winter cycle, check the opening of the refrigerant valves.
P05	Detection of absence of one phase or incorrect phase connection in the three-phase version. Lack of neutral in single-phase versions.	Check the presence and sequence of the power supply phases R, S, and T, and in single-phase systems ensure the appliance is not powered by two phases.
P10	Missing or disconnected electrical bridge on connector CN034 of the PAW-ACXA73-38670 board.	Check the connection.
P11	Missing or disconnected electrical bridge on connector CN068 of the PAW-ACXA73-38670 board.	Check the connection.

Alarms displayed	Cause	Remedy
P13	Alarm valve open	Check only performed in Test Run. Check if valves are open and system charged with sufficient refrigerant.
P15	Detection of insufficient refrigerant charge.	Check the refrigeration circuit for potential leaks.
P14	O2 sensor detection	Where applicable, check for connections to the indoor unit EXCT plug. Remove connection and adjust settings accordingly.
P16	Excessive compressor absorption.	Check resistance values.
P19	4 way valve stuck	Check the power supply and the operation of the 4-way valve.
P20	Refrigerant high-pressure protection.	Check the cleanliness of the external heat exchanger and ensure minimum clearances are maintained. Check fan operation and proper discharge of air from the condenser.
P22	External fan motor malfunctioning. Protection of the external fan inverter circuit activated.	Check for free movement of the fan. Replace the fan motor inverter board.
P31	Group control error	Error from other units within group. Check for group wiring between indoor units and investigate which units are in fault.
P26	Intervention of the compressor inverter circuit protection.	Remove and restore power to the appliance and check the correct restart of the compressor.
P29	The compressor is not functioning correctly.	Check the wiring of the Inverter board and replace it if necessary.
H01	Overcurrent detected by the compressor's Inverter board.	The radiant plate cooling issue of the Inverter board. Check the cleanliness of the heatsink. Check the electrical connections of the compressor.
H02	PAM issues. Error is detected by over-voltage and overcurrent of DC side.	Check supply voltage is within the allowable range, and confirm connections to the HIC are securely located.
H03	Primary CT current sensor failure (TO)	Check if no current is detected while compressor is running, replace CR board.
H05	The control board software of the external unit needs updating	Contact the Technical Support Center to arrange for the replacement.
H31	Malfunction of the HIC driver board	Contact the Technical Support Center to arrange for the replacement.
F01	The liquid sensor E1 on the indoor unit is disconnected, interrupted, or short-circuited.	Check the sensor and consider replacing it if needed.
F02	The condensation sensor E2 on the indoor unit is disconnected, interrupted, or short-circuited.	Check the sensor and consider replacing it if needed.
F04	The compressor discharge sensor TD is disconnected, interrupted, or short-circuited.	Check the sensor and consider replacing it if needed.
F06	The liquid sensor C1 on the outdoor unit's coil is disconnected, interrupted, or short-circuited.	Check the sensor and consider replacing it if needed.
F07	The condensation sensor C2 on the outdoor unit's coil is disconnected, interrupted, or short-circuited.	Check the sensor and consider replacing it if needed.
F08	The outdoor temperature sensor TO is disconnected, interrupted, or short-circuited.	Check the sensor and consider replacing it if needed.
F10	The regulation signal connection of the controller is disconnected, interrupted, or short-circuited.	Check the connection of the Tout connector and the controller INN-PDC_03 to the CN104 connector of the PAW-ACXA73-38670 board.
F12	The compressor suction sensor TS is disconnected, interrupted, or short-circuited.	Check the sensor and consider replacing it if needed.
F29	EEProm problem in the outdoor unit.	Switch the appliance off and on again and check for proper operation. Replace the EEPROM of the PAW-ACXA73-38670 board.
F31	EEProm problem in the outdoor unit.	Switch the appliance off and on again and check for proper operation. Replace and reprogram the electronic board of the outdoor unit.

Alarms displayed	Cause	Remedy
L02	Parameter incompatibility between the indoor and outdoor unit.	Perform the automatic address setting again. Contact the Service for reprogramming.
L04	Duplicate address of the outdoor unit	
L08	Lack of settings in the outdoor unit.	
L09	Lack of settings in the outdoor unit.	
L10	Lack of settings in the outdoor unit.	
L13	Incorrect parameter setting in the indoor unit.	
L18	Malfunction of 4 way valve. The probes E1 and E2 detect low temperatures during heating. The probes E1 and E2 detect high temperatures during cooling.	It could be a transitory situation. Switch the appliance off and on again and check for proper operation.
E01	Automatic address setting was not completed. The wirings between the indoor and outdoor units are cut or not properly connected.	Check the connection between the indoor and outdoor units, and or local commissioning controller.
E03	Error in Indoor Unit Receiving Signal from Remote Controller	
E04	Error in receiving signals from the Outdoor unit.	
E06	Communication problems between the outdoor and indoor units.	
E07	Communication problems between the outdoor and indoor units.	
E08	Duplicate indoor unit address setting error	Only checked when multiple systems are connected within a group. Check address settings and correct accordingly.
E09	More than one remote control is set to main error	Only considered if more than one Commissioning Control is connected. Adjust Main / Sub setting or remove one of the controls.
E12	Automatic address setting start is prohibited while automatic address setting is in progress	Check wiring. Reset system and perform automatic addressing again.
E14	Duplicate main unit in multi-control simultaneous operation	Only considered when more than one system is connected within a control group. Check detailed settings and adjust accordingly.
E15	The capacity setting of the indoor unit is lower than that of the outdoor unit.	Check the sizes of the unit and have the indoor unit reconfigured.
E16	The capacity setting of the outdoor unit is lower than that of the indoor unit.	Check the sizes of the unit and have the indoor unit reconfigured.
E18	Faulty communication in group control wiring	Only considered when more than one system is connected within a control group. Check group wiring and potential failure of indoor unit main PCB.
E20	Automatic addressing procedure interrupted.	Check the connection between the indoor and outdoor units.
E31	Communication problems between the outdoor and indoor units.	

10.4 M7 alarms

Alarms displayed	Description
A0X	Communication error with fan number X
A1X	Fan number X is faulty or does not follow the target value correctly
A2X	Communication error with M7 number X
A30	Internal coil sensor failure
A31	Intake air sensor failure
A32	Outlet air sensor failure

11. TECHNICAL INFORMATION

11.1 Technical data

Indoor unit (single-phase)

Kit	u.m.	KIT-71PQ41Z5	KIT-100PQ41Z5	KIT-100PQ51Z5	KIT-125PQ51Z5	KIT-140PQ51Z5
Models	u.m.	S-7110PQ41E	S-7110PQ41E	S-1014PQ51E	S-1014PQ51E	S-1014PQ51E
Heating performance (A7/6; A20) (1)						
Nominal total capacity	kW	9,4	10,32	9,7	12	13,3
Minimum total capacity	kW	2,2	3	3	3,3	3,5
Maximum total power output	kW	9,4	13,2	11,5	15,2	15,9
COP (nominal)	-	3,88	4,77	4,44	3,43	3,61
SCOP / η _{s,c} 1)	-	4,27 A+	4,3 A+	4,46 A+	143%	143%
Power rating at -10°C	kW	5,98	8,96	7,96	10,30	10,08
Cooling performance (A35; A27/19) (3)						
Power Rated Total Output	kW	8,5	9,86	9,77	12,22	13,67
Minimum total output power	kW	2,7	3	3,1	3,3	3,4
Maximum total output power	kW	8,5	11	11,5	13,7	14,8
EER (nominal)	-	3,47	3,54	3,46	3,28	3,14
SEER / η _{s,c} 1)	-	6,5 A++	6,17 A++	6,41 A++	245%	248%
Aeraulic performance						
Air flow rate Hi / Med / Lo	m ³ /h	1800 / 1520 / 1120	1800 / 1520 / 1120	2250 / 1900 / 1400	2250 / 1900 / 1400	2250 / 1900 / 1400
Useful head nom (min - max) 2)	Pa	50 (0 - 150)	50 (0 - 150)	50 (0 - 150)	50 (0 - 150)	50 (0 - 150)
Sound levels during heating						
Internal Sound Pressure (Hi)	dB (A)	38,0	38,0	40,0	40,0	40,0
Internal Sound Pressure (Med)	dB (A)	32,0	32,0	36,0	36,0	36,0
Internal Sound Pressure (Lo)	dB (A)	28,0	28,0	30,0	30,0	30,0
Internal sound power (Hi)	dB (A)	60,0	60,0	63,0	63,0	63,0
Internal Sound Power (Med)	dB (A)	55,0	55,0	59,0	59,0	59,0
Internal sound power (Lo)	dB (A)	51,0	51,0	53,0	53,0	53,0
Ambient air intake fan						
Number	Nr.	4	4	5	5	5
Product dimensions						
Width	mm	1244	1244	1454	1454	1454
Depth	mm	696	696	696	696	696
Height	mm	265	265	265	265	265
Weight	kg	52	52	61	61	61
Single zone fancoil aeraulic performance						
Nominal cooling output (min - max)	kW	2,13 (0,68-2,13)	2,47 (0,75-2,75)	1,95 (0,62-2,3)	2,44 (0,66-2,74)	2,73 (0,68-2,96)
Nominal heating output power (min - max)	kW	2,35 (0,55-2,35)	2,58 (0,75-3,3)	1,94 (0,6-2,3)	2,4 (0,66-3,04)	2,66 (0,7-3,18)
Useful head nom (min - max) 2)	Pa	50 (0 - 150)	50 (0 - 150)	50 (0 - 150)	50 (0 - 150)	50 (0 - 150)
Air flow rate Hi / Med / Lo	m ³ /h	450 / 380 / 280	450 / 380 / 280	450 / 380 / 280	450 / 380 / 280	450 / 380 / 280
1) For models below 12 kW, the SEER and SCOP is calculated based on values of EU/626/2011. For models above 12 kW, the η _{s,c} / η _{s,h} values is calculated based on EN 14825.						
2) Medium external static pressure setting from factory.						
3) Outdoor unit located lower / outdoor unit located higher.						
* Recommended fuse for the indoor 3 A.						

Outdoor unit (single-phase)

Kit	u.m.	KIT-71PQ41Z5	KIT-100PQ41Z5	KIT-100PQ51Z5	KIT-125PQ51Z5	KIT-140PQ51Z5
Models		U-71PZ3E5A	U-100PZ3E5	U-100PZ3E5	U-125PZ3E5	U-140PZ3E5
Air performance in heating						
Maximum air flow	m ³ /min	46	73	73	80	82
Air performance in cooling						
Maximum air flow	m ³ /min	45	73	73	82	84
Refrigeration circuit						
Refrigerant type	-	R32				
Refrigerant quantity / CO2 eq.	kg / T	1,32 / 0,89	2,40 / 1,62	2,40 / 1,62	2,80 / 1,89	2,80 / 1,89
Pipe diameter (liquid)	Inch (mm)	1/4 (ø6,35)	3/8 (ø9,52)	3/8 (ø9,52)	3/8 (ø9,52)	3/8 (ø9,52)
Pipe diameter (gas)	Inch (mm)	5/8 (ø15,88)	5/8 (ø15,88)	5/8 (ø15,88)	5/8 (ø15,88)	5/8 (ø15,88)
Pipe length (min - max)	m	3 - 40	5 - 50	5 - 50	5 - 50	5 - 50
Altitude difference (in / out) 3)	m	20 / 30	15 / 30	15 / 30	15 / 30	15 / 30
Preloaded hose length	m	30	30	30	30	30
Additional charge	g/m	17	45	45	45	45
Noise levels during heating						
Sound power transmitted to the structure Lw	dB (A)	68,0	70,0	70,0	73,0	74,0
Average sound pressure at 1 m Lp	dB (A)	49,0	52,0	52,0	55,0	56,0
Sound levels in cooling						
Sound power transmitted to the structure Lw	dB (A)	66,0	70,0	70,0	73,0	74,0
Average sound pressure at 1 m Lp	dB (A)	48,0	52,0	52,0	55,0	56,0
Electrical characteristics						
Power supply (min - nom - max)	V	220 - 230 - 240	220 - 230 - 240	220 - 230 - 240	220 - 230 - 240	220 - 230 - 240
Maximum cooling current consumption (min - nom - max)	A	9,95-9,50-9,10	13,30 - 12,70 - 12,20	13,30 - 12,70 - 12,20	17,20 - 16,40 - 15,80	20,50 - 19,60 - 18,8
Maximum heating current consumption (min - nom - max)	A	7,90-7,55-7,25	11,60 - 11,10 - 10,60	11,60 - 11,10 - 10,60	16,40 - 15,70 - 15,00	17,20 - 16,40 - 15,80
Limits in heating						
Minimum outside air temperature	°C	-15	-15	-15	-15	-15
Maximum outdoor air temperature	°C	24	24	24	24	24
Limits in cooling						
Minimum outside air temperature	°C	-10	-10	-10	-10	-10
Maximum outdoor air temperature	°C	43	43	43	43	43
Product dimensions						
Length	mm	875	980	980	980	980
Depth	mm	320	370	370	370	370
Height	mm	695	996	996	996	996
Weight	kg	50,0	83,0	83,0	87,0	87,0
1) For models below 12 kW, the SEER and SCOP is calculated based on values of EU/626/2011. For models above 12 kW, the η _{s,c} / η _{s,h} values is calculated based on EN 14825.						
2) Medium external static pressure setting from factory.						
3) Outdoor unit located lower / outdoor unit located higher.						
* Recommended fuse for the indoor 3 A.						

Indoor unit (three-phase)

Kit	u.m.	KIT-100PQ41Z8	KIT-100PQ51Z8	KIT-125PQ51Z8	KIT-140PQ51Z8
Models	u.m.	S-7110PQ41E	S-1014PQ51E	S-1014PQ51E	S-1014PQ51E
Heating performance (A 7/6; A 20) (1)					
Nominal total capacity	kW	10,32	9,7	12	13,3
Minimum total capacity	kW	3	3	3,3	3,5
Maximum total power output	kW	13,2	11,5	15,2	15,9
COP (nominal)	-	4,77	4,44	3,43	3,61
SCOP / $\eta_{s,c} 1$)	-	4,3 A+	4,46 A+	143%	143%
Power rating at -10°C	kW	8,96	7,96	10,30	10,08
Cooling performance (A 35; A 27/19) (3)					
Power Rated Total Output	kW	9,86	9,77	12,22	13,67
Minimum total output power	kW	3	3,1	3,3	3,4
Maximum total output power	kW	11	11,5	13,7	14,8
EER (nominal)	-	3,54	3,46	3,28	3,14
SEER / $\eta_{s,c} 1$)	-	6,17 A++	6,41 A++	245%	248%
Aeraulic performance					
Air flow rate Hi / Med / Lo	m ³ /h	1800 / 1520 / 1120	2250 / 1900 / 1400	2250 / 1900 / 1400	2250 / 1900 / 1400
Useful head nom (min - max) 2)	Pa	50 (0 - 150)	50 (0 - 150)	50 (0 - 150)	50 (0 - 150)
Sound levels during heating					
Internal Sound Pressure (Hi)	dB (A)	38,0	40,0	40,0	40,0
Internal Sound Pressure (Med)	dB (A)	32,0	36,0	36,0	36,0
Internal Sound Pressure (Lo)	dB (A)	28,0	30,0	30,0	30,0
Internal sound power (Hi)	dB (A)	60,0	63,0	63,0	63,0
Internal Sound Power (Med)	dB (A)	55,0	59,0	59,0	59,0
Internal sound power (Lo)	dB (A)	51,0	53,0	53,0	53,0
Ambient air intake fan					
Number	Nr.	4	5	5	5
Product dimensions					
Width	mm	1244	1454	1454	1454
Depth	mm	696	696	696	696
Height	mm	265	265	265	265
Weight	kg	52	61	61	61
Single zone fancoil aeraulic performance					
Nominal cooling output (min - max)	kW	2,47 (0,75-2,75)	1,95 (0,62-2,3)	2,44 (0,66-2,74)	2,73 (0,68-2,96)
Nominal heating output power (min - max)	kW	2,58 (0,75-3,3)	1,94 (0,6-2,3)	2,4 (0,66-3,04)	2,66 (0,7-3,18)
Useful head nom (min - max) 2)	Pa	50 (0 - 150)	50 (0 - 150)	50 (0 - 150)	50 (0 - 150)
Air flow rate Hi / Med / Lo	m ³ /h	450 / 380 / 280	450 / 380 / 280	450 / 380 / 280	450 / 380 / 280
1) For models below 12 kW, the SEER and SCOP is calculated based on values of EU/626/2011. For models above 12 kW, the $\eta_{s,c}$ / $\eta_{s,h}$ values is calculated based on EN 14825.					
2) Medium external static pressure setting from factory.					
3) Outdoor unit located lower / outdoor unit located higher.					
* Recommended fuse for the indoor 3 A.					

Outdoor unit (three-phase)

Kit	u.m.	KIT-100PQ41Z8	KIT-100PQ51Z8	KIT-125PQ51Z8	KIT-140PQ51Z8
Modelli		U-100PZ3E8	U-100PZ3E8	U-125PZ3E8	U-140PZ3E8
Air performance in heating					
Maximum air flow	m ³ /min	73	73	80	82
Refrigeration circuit					
Maximum air flow	m ³ /min	73	73	82	84
Refrigeration circuit					
Refrigerant type	-	R32			
Refrigerant quantity / CO2 eq.	kg / T	2,40 / 1,62	2,40 / 1,62	2,80 / 1,89	2,80 / 1,89
Pipe diameter (liquid)	Inch (mm)	3/8 (ø9,52)	3/8 (ø9,52)	3/8 (ø9,52)	3/8 (ø9,52)
Pipe diameter (gas)	Inch (mm)	5/8 (ø15,88)	5/8 (ø15,88)	5/8 (ø15,88)	5/8 (ø15,88)
Pipe length (min - max)	m	5 - 50	5 - 50	5 - 50	5 - 50
Altitude difference (in / out) 3)	m	15 / 30	15 / 30	15 / 30	15 / 30
Preloaded hose length	m	30	30	30	30
Additional charge	g/m	45	45	45	45
Noise levels during heating					
Sound power transmitted to the structure Lw	dB (A)	70,0	70,0	73,0	74,0
Average sound pressure at 1 m Lp	dB (A)	52,0	52,0	55,0	56,0
Sound levels in cooling					
Sound power transmitted to the structure Lw	dB (A)	70,0	70,0	73,0	74,0
Average sound pressure at 1 m Lp	dB (A)	52,0	52,0	55,0	56,0
Electrical characteristics					
Power supply (min - nom - max)	V	380 - 400 - 415	380 - 400 - 415	380 - 400 - 415	380 - 400 - 415
Maximum cooling current consumption (min - nom - max)	A	4,45 - 4,20 - 4,05	4,45 - 4,20 - 4,05	5,75 - 5,45 - 5,25	6,85 - 6,50 - 6,30
Maximum heating current consumption (min - nom - max)	A	3,85 - 3,70 - 3,55	3,85 - 3,70 - 3,55	5,50 - 5,20 - 5,05	5,75 - 5,45 - 5,25
Limits in heating					
Minimum outside air temperature	°C	-15	-15	-15	-15
Maximum outdoor air temperature	°C	24	24	24	24
Limits in cooling					
Minimum outside air temperature	°C	-10	-10	-10	-10
Maximum outdoor air temperature	°C	43	43	43	43
Product dimensions					
Length	mm	980	980	980	980
Depth	mm	370	370	370	370
Height	mm	996	996	996	996
Weight	kg	83,0	83,0	87,0	87,0
1) For models below 12 kW, the SEER and SCOP is calculated based on values of EU/626/2011. For models above 12 kW, the $\eta_{s,c}$ / $\eta_{s,h}$ values is calculated based on EN 14825.					
2) Medium external static pressure setting from factory.					
3) Outdoor unit located lower / outdoor unit located higher.					
* Recommended fuse for the indoor 3 A.					

11.2 Dimensions

Model 7110

A	Power supply
B	Horizontal condensate drain Ø18mm
C	Vertical condensate drain Ø18mm
D	Male flange Ø160

E	Electrical panel
F	Gas connections
G	Fixing bracket

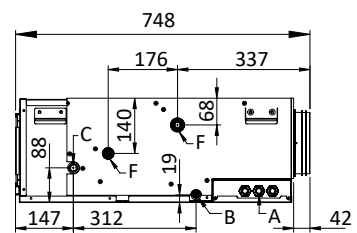
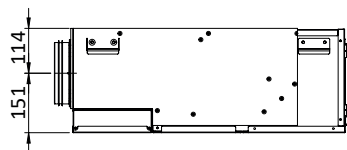
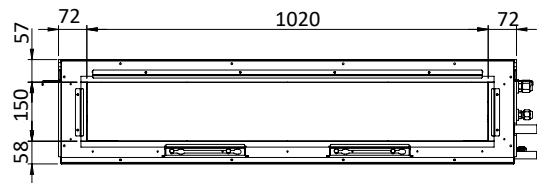
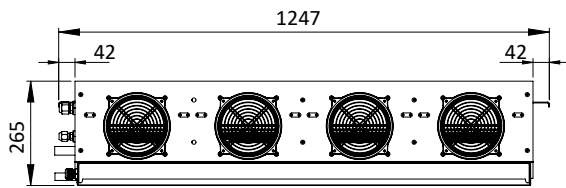
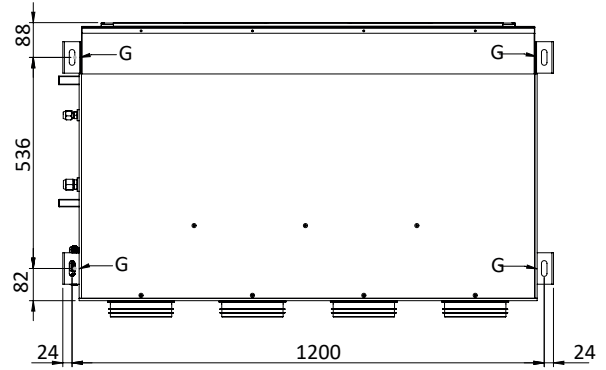
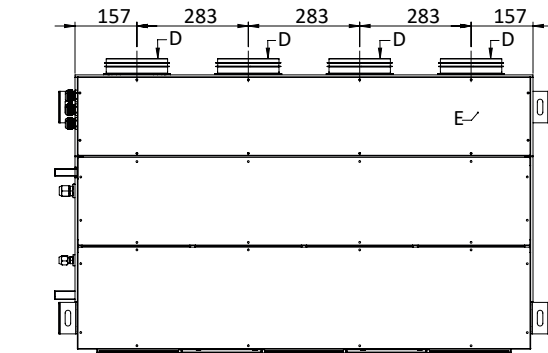

Model 1014

A	Power supply	E	Electrical panel
B	Horizontal condensate drain Ø18mm	F	Gas connections
C	Vertical condensate drain Ø18mm	G	Fixing bracket
D	Male flange Ø160		

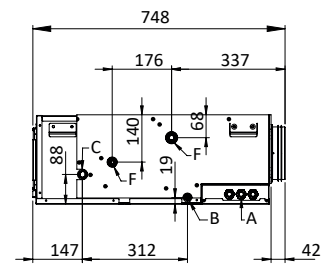
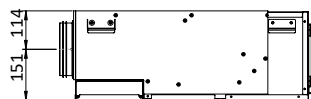
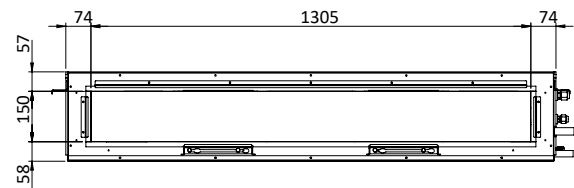
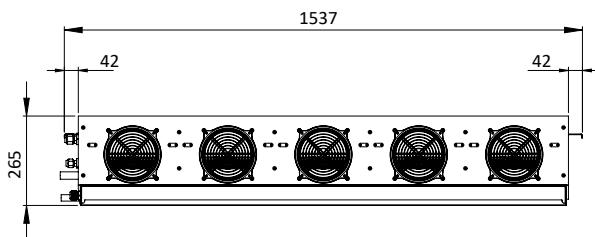
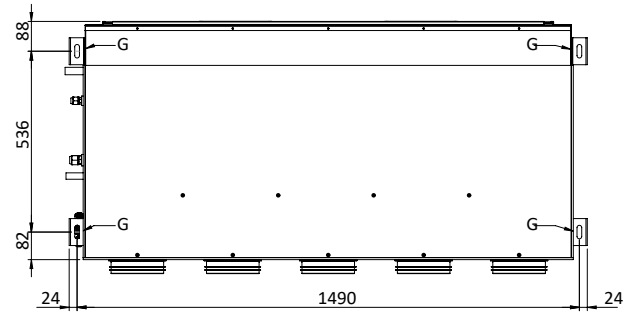
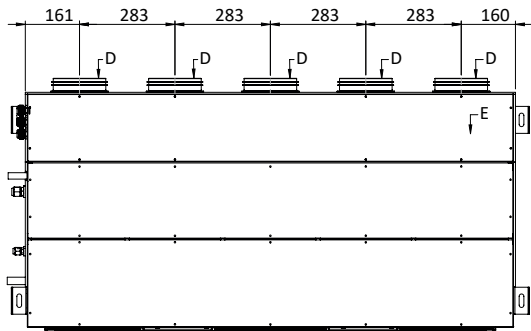

11.4 Pressure/ventilation curves

TABLE PRESSURE SETTING / LEVEL / RPM

	HIGH (150pa)	MED (100pa)	LOW (DEFAULT 50pa)	SUPER LOW (0pa)
Pa	150	100	50	0
R1 (rpm set)	1250	1050	850	650
R2 (rpm set)	1450	1250	1050	850
R3 (rpm set)	1650	1450	1250	1050
R4 (rpm set)	2000	1650	1450	1250
R5 (rpm set)	2400	2000	1650	1450

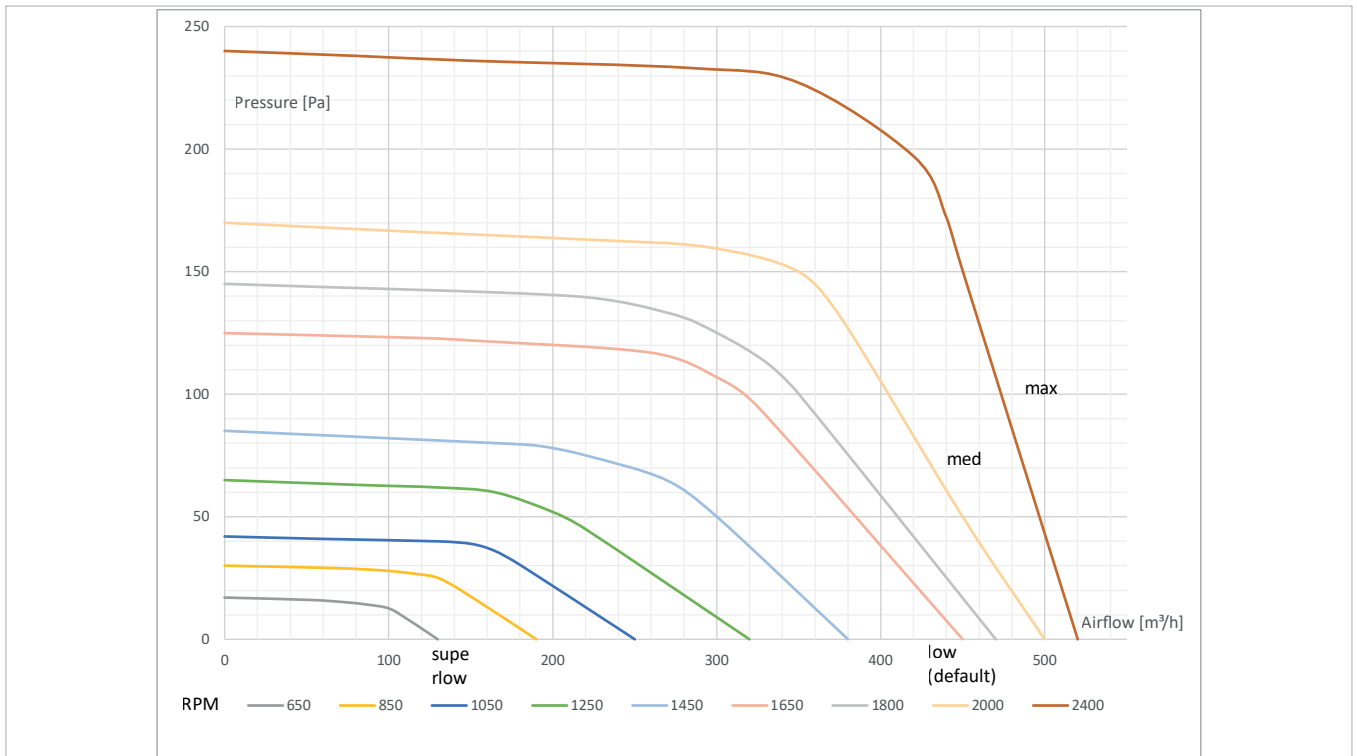

12. GENERAL FEATURES

12.1 Accessory pairing

Air delivery accessories

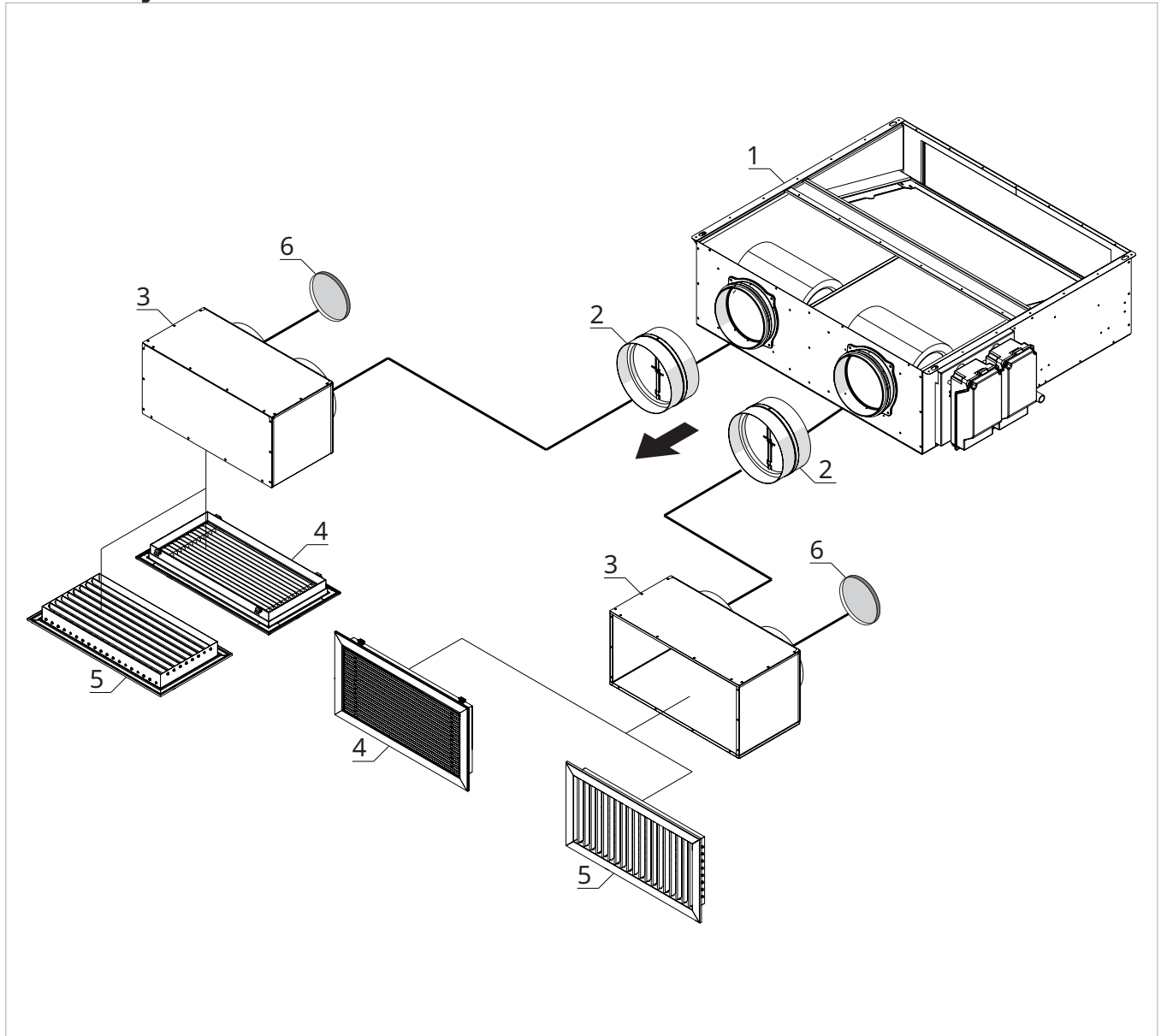

- | | |
|----|---|
| 1. | Unit |
| 2. | Non-return damper |
| 3. | Insulated plenum for horizontal or vertical supply/return with two DN 160 mm inlets and grille connection |
| 4. | Suction grille with removable aluminum filter |
| 5. | Aluminum supply grille with double row of adjustable louvers |
| 6. | Plug for inlet closure (to be installed by the installer) |

⚠ Backdraft dampers are not mandatory for installation.
They are to be considered accessories.

Air return accessories

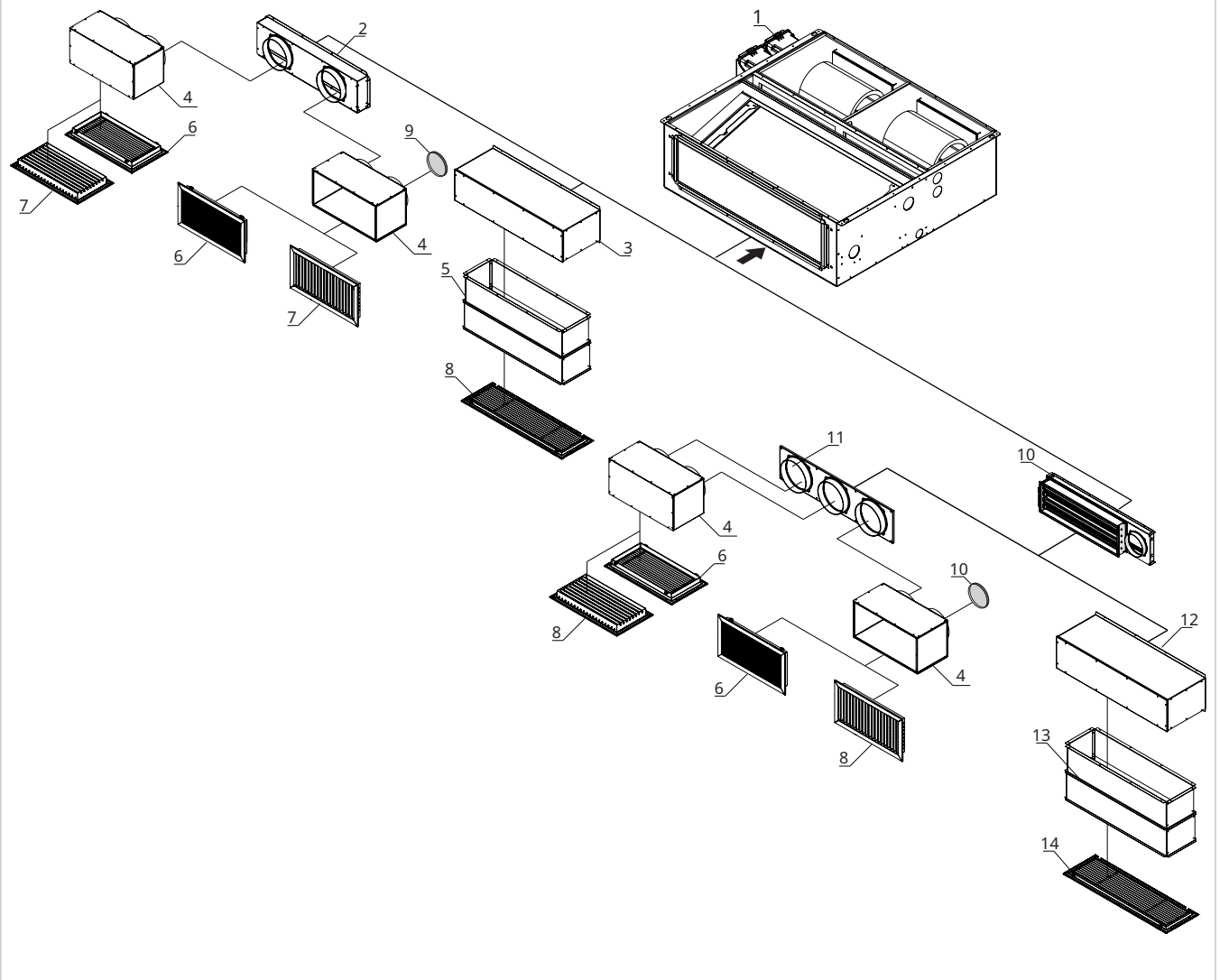

1. Unit
2. Return plenum
3. Plenum kit for rear intake
4. Insulated plenum for horizontal or vertical supply/return with two DN 160 inlets and grille connection
5. Telescopic kit for rear or directly coupled suction
6. Suction grille with removable aluminum filter
7. Aluminum supply grille with double row of adjustable louvers
8. Grille for telescopic kit for rear intake
9. Plug for inlet closure (to be installed by the installer)
10. Plenum kit for external air connection with damper for room recirculation
11. Plate for ducting damper for external air
12. Rear intake plenum kit for external air kit
13. Telescopic kit for rear intake or directly coupled to external air damper
14. Grille for telescopic kit for external air damper

13. TECHNICAL CHARACTERISTICS OF ACCESSORIES

13.1 Mounting

Unit / accessory ducting

For ducting using flexible ducts: SCE016010 - SCE116010 - SCE316010

If male nipple:

- ▶ remove the gasket by pulling it outward

1. Male nipple

2. Gasket

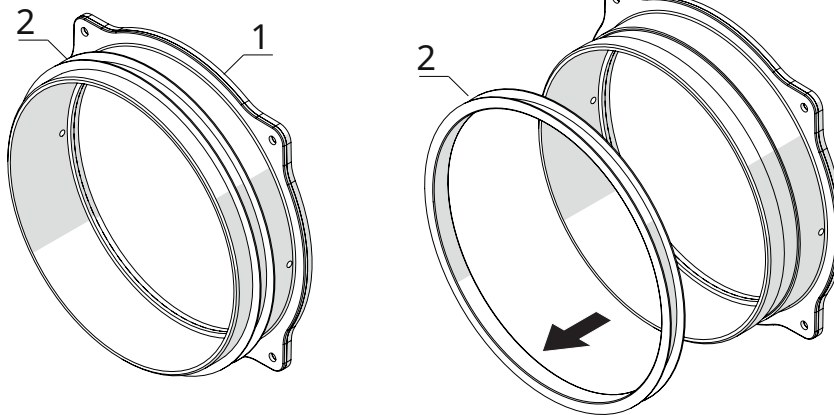

- ▶ insert the pipe into the junction
- ▶ preferably position the clamp in the gasket seat
- ▶ tighten the clamp to secure the pipe

1. Flexible duct: SCE016010 - SCE116010 - SCE316010

2. Clamp

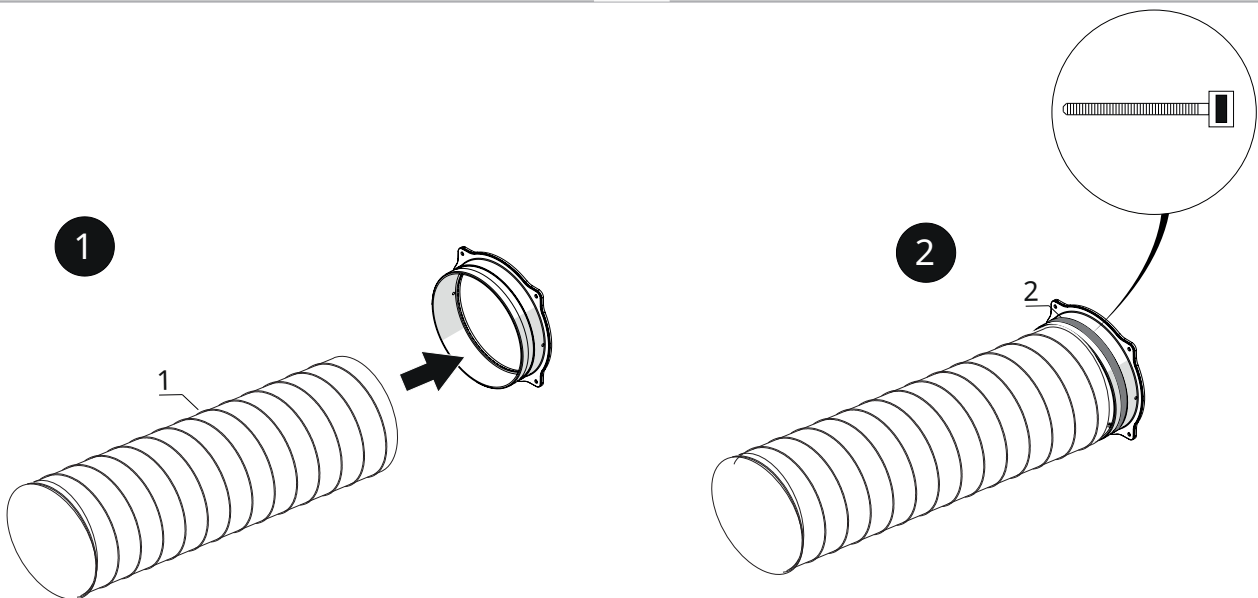

⚠ It is advisable to use the gasket recess as the clamp seat.

If female flange:

► insert the pipe into the female flange

1. Clamp

2. Flexible duct: SCE016010 - SCE116010 - SCE316010

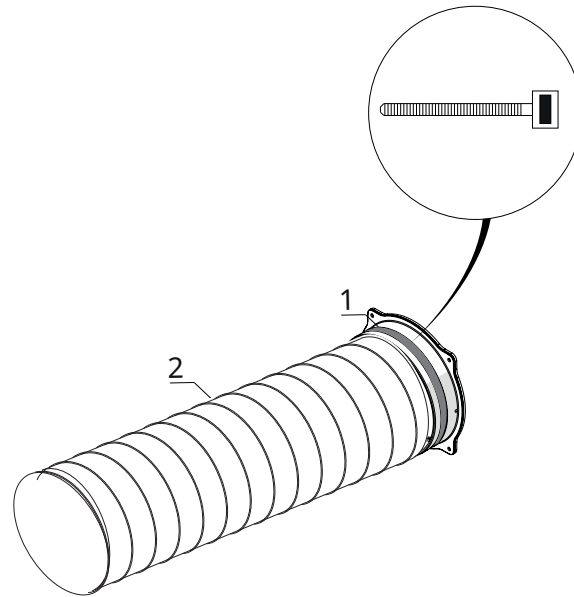

Non-return damper

1. Unit

2. Backdraft damper AHRD0519

3. Sleeve

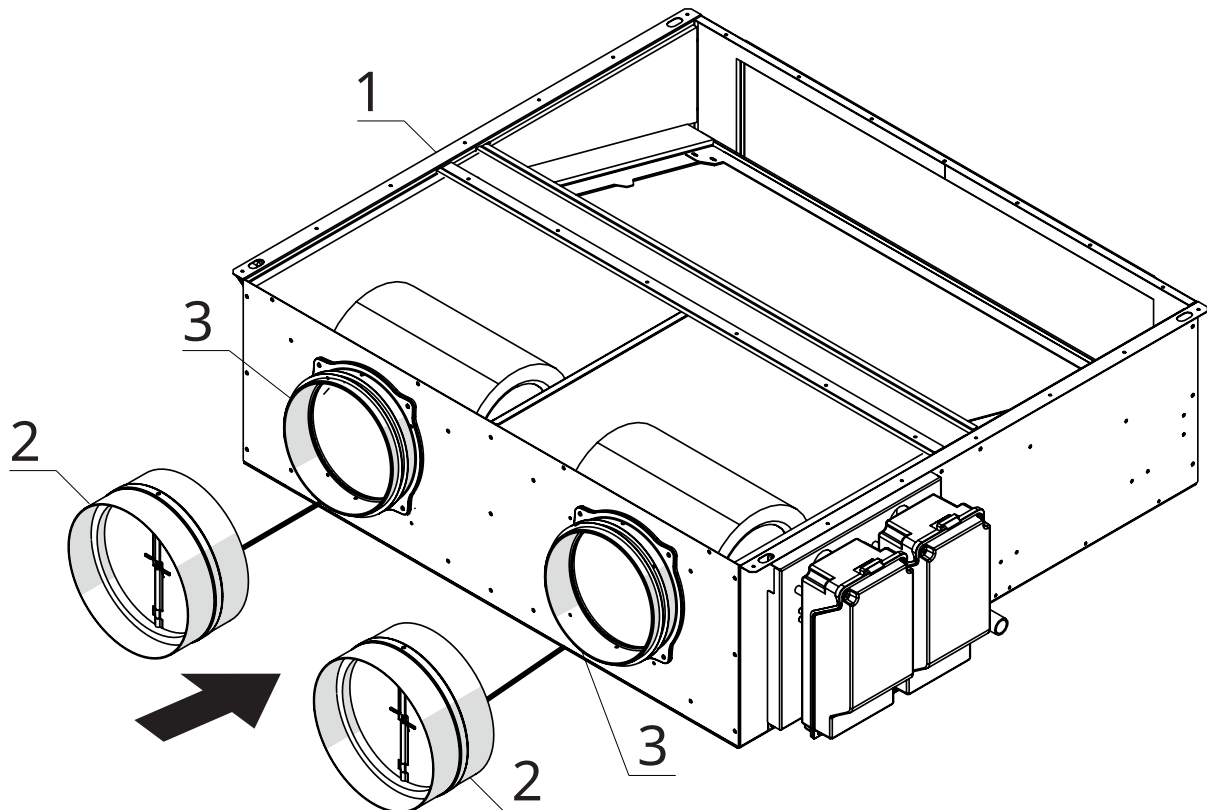

► Snap-fit the backdraft damper into the sleeves

⚠ Check the orientation of the damper before installing it

Insulated plenum for horizontal or vertical air supply / return with two DN 160 mm inlets and grille connection

- 1. Insulated plenum for horizontal or vertical air supply / return with two DN 160 mm inlets and grille connection (AHRA0708)
- 2. Duct

- 3. Plug for inlet closure (to be installed by the installer)
- 4. Clamp

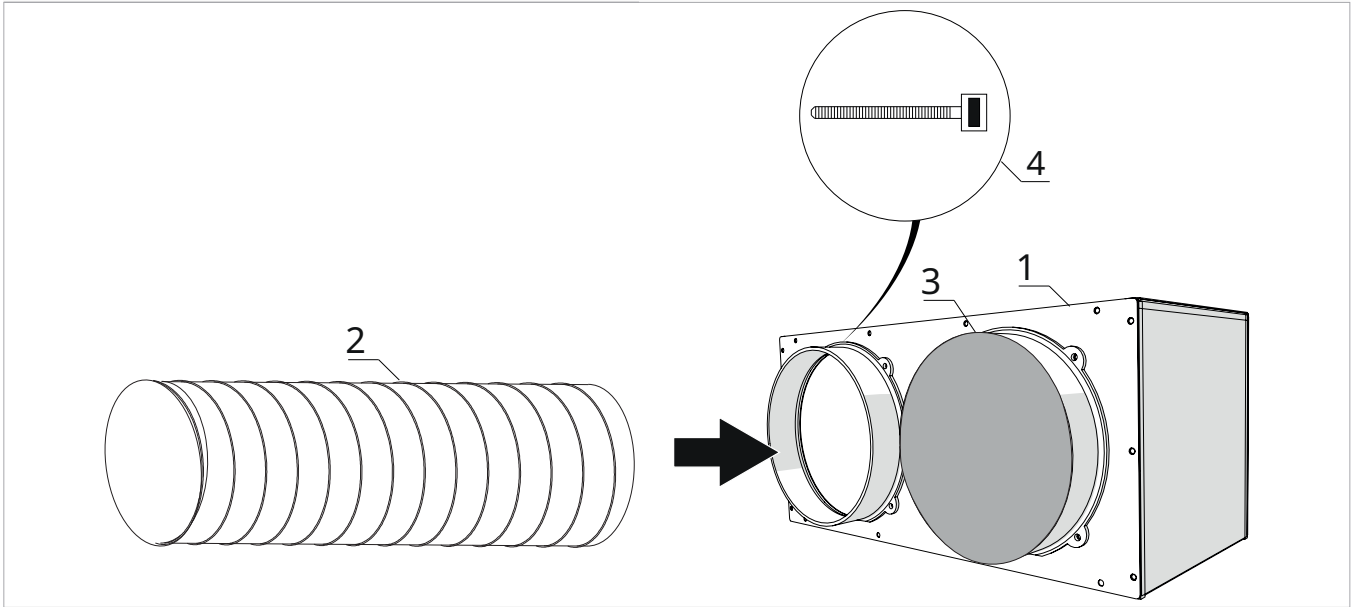

Connection via ducting

- ▶ align the duct with the plenum inlet
- ▶ insert the duct into the plenum

The inlet closure cap allows one of the two plenum inlets to be closed, depending on the desired configuration. Insert by pressing until fully locked.

- ⚠ The inlet closure cap is supplied as standard.
- ⚠ The duct and clamp are not supplied as standard.

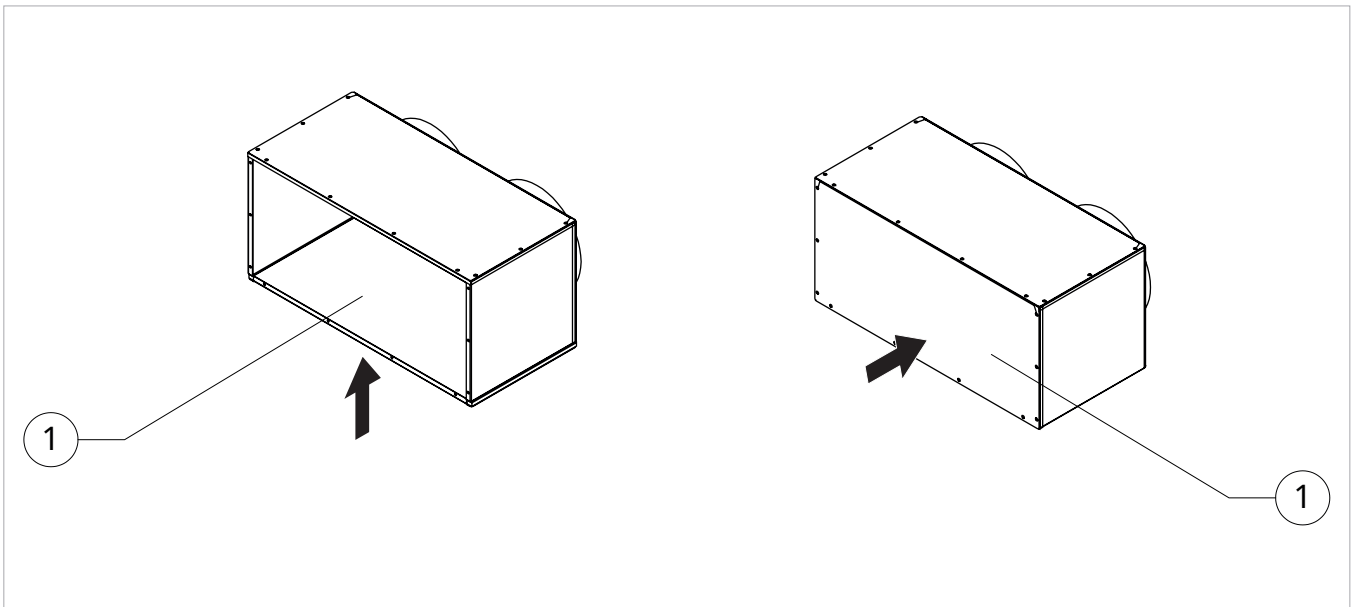

- ⚠ To modify the configuration, unscrew the panel, make the selection and screw it back on

Intake grille with removable aluminium filter and aluminium supply grille with double row of adjustable fins

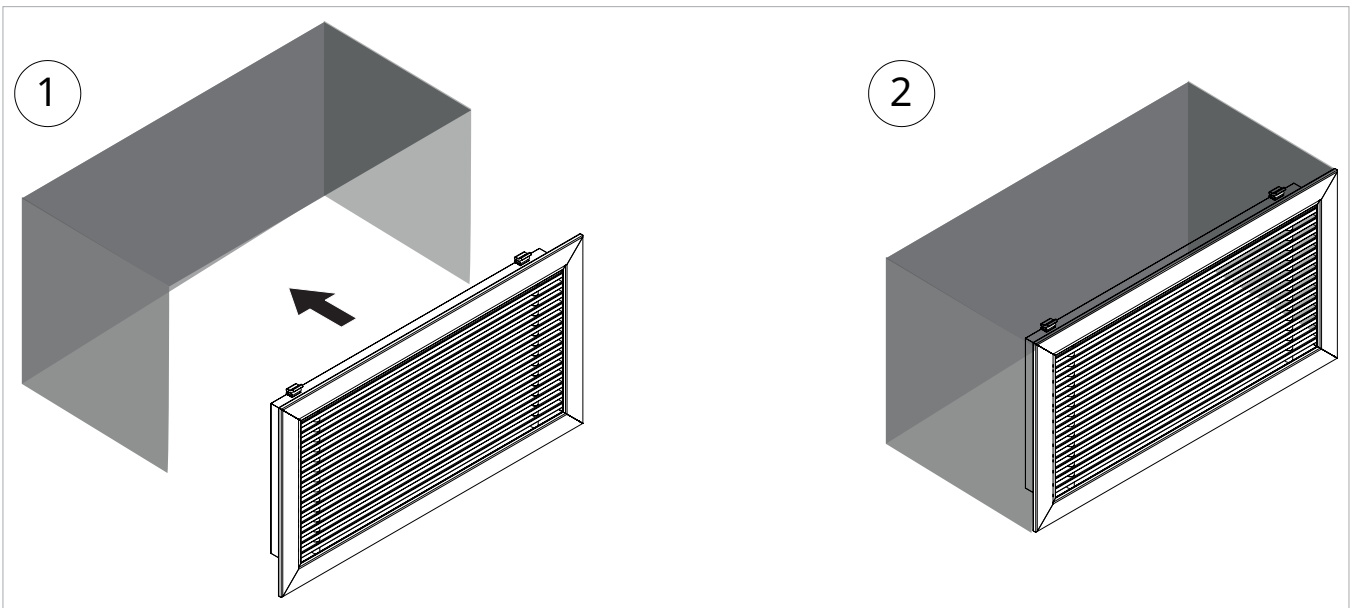

⚠ The coupling is snap-fit

Filter replacement

1. Grille: AHRA0709 - AHRA0710 (filter not included)
2. Filter

3. Grille fixing clips

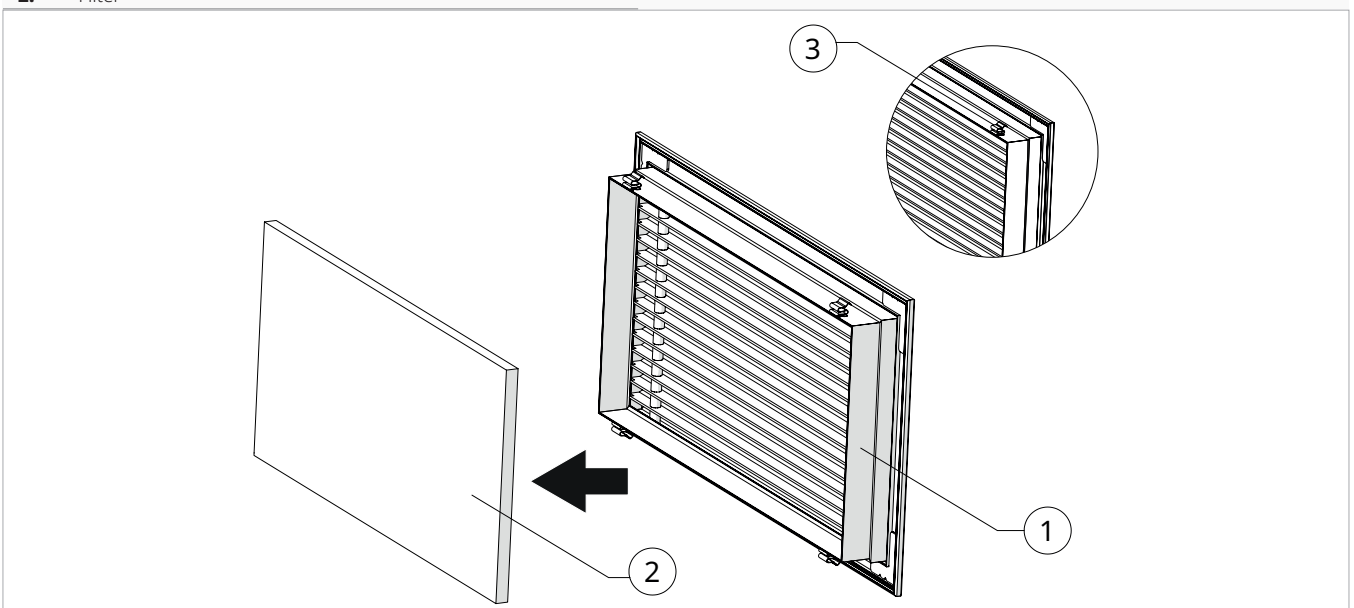

- ▶ Remove the used filter from the grille
- ▶ Insert the new filter or clean the filter

⚠ The filter is already inserted directly into the grille

⚠ The filter is not included in the AHRA0709 supply grille

Plenum kit for external air connection with damper for room recirculation

Description

The external air kit compatible with fan coil units includes a recirculation damper equipped with an electromechanical actuator that precisely controls the recirculated air flow, along with an air intake that ensures the supply of external air.

- 1. Support frame
- 2. Damper Plate and External Air Intake

- 3. Filter port

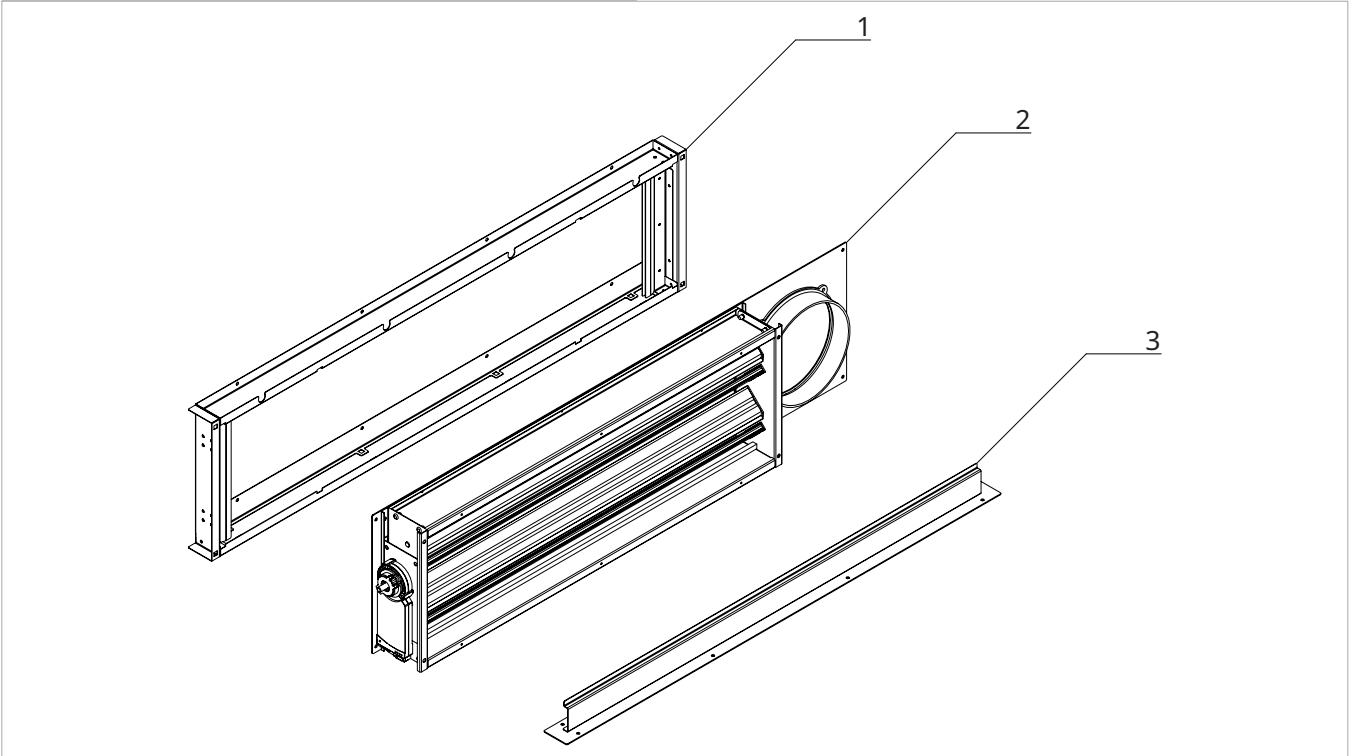

Installation

To prepare for the accessory assembly:

- ▶ remove the filter guides from the unit by unscrewing the screws.

- ▶ remove the filter

- 1. Filter guides

- 2. Filter

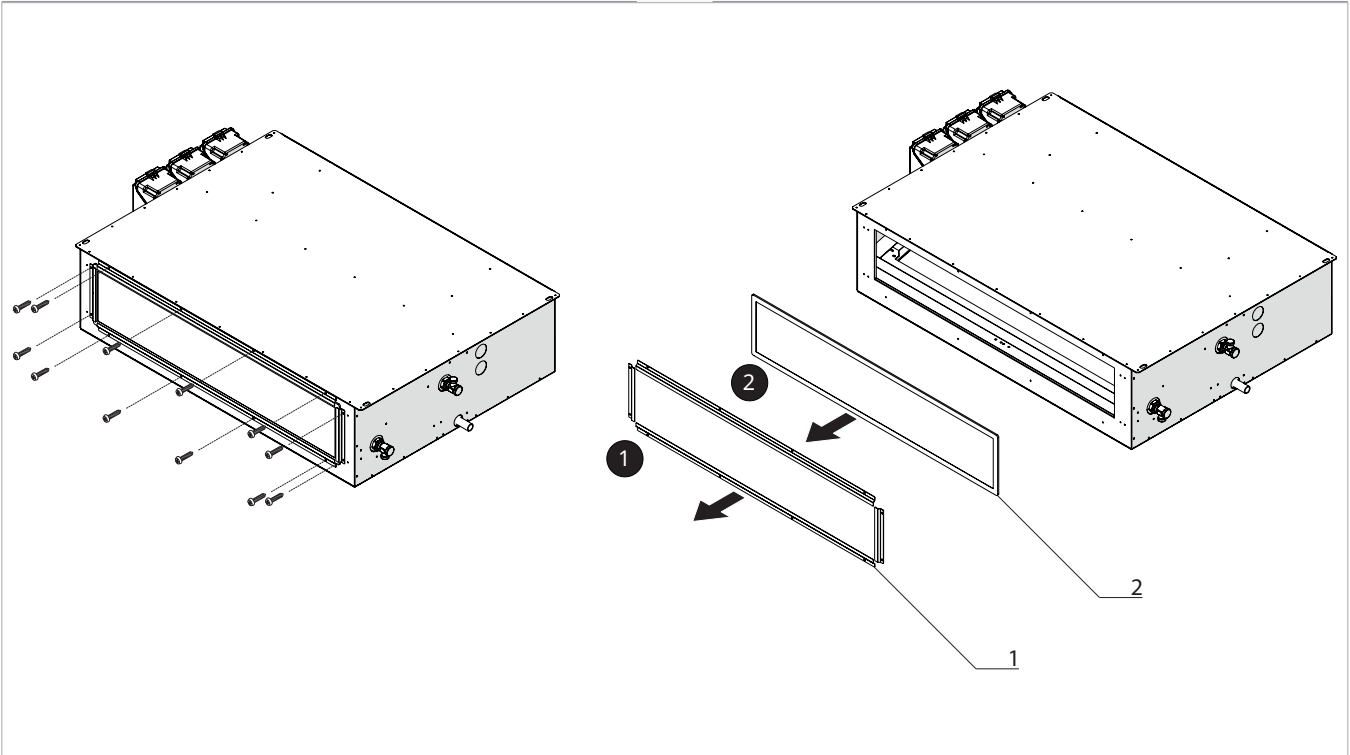

To install the support frame:

- ▶ Use the previously removed screws

- ▶ secure the support frame

- ▶ insert the filter into the support frame guides

1. Support frame

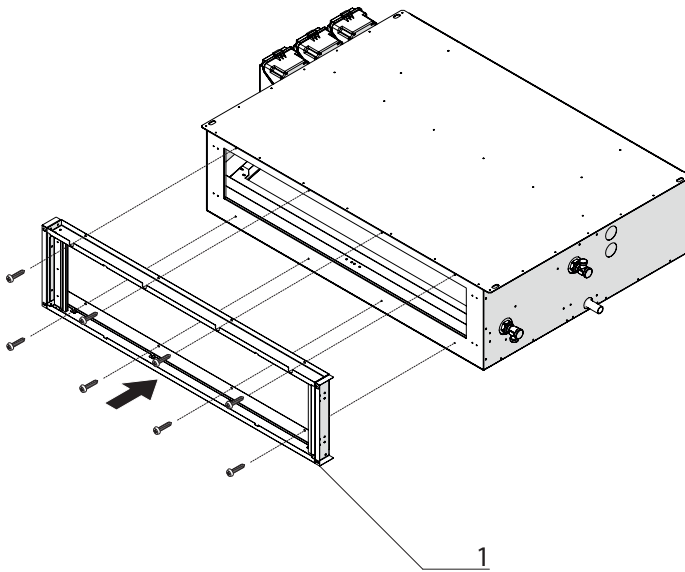

2. Filter

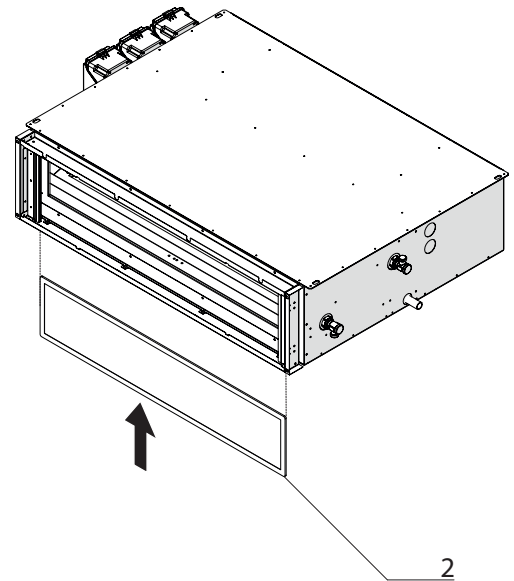
**To install the filter port:**

► use the provided screws

► secure the filter port

1. Filter port

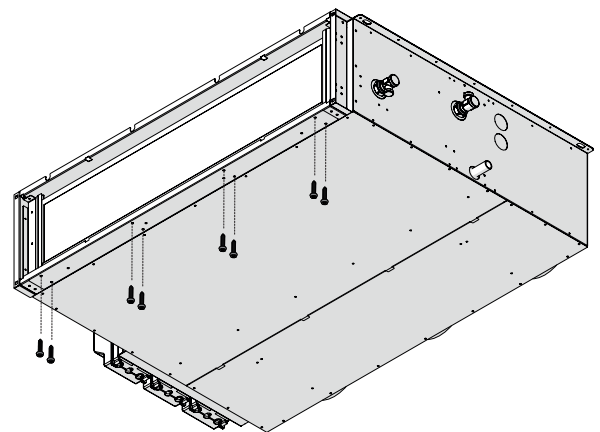
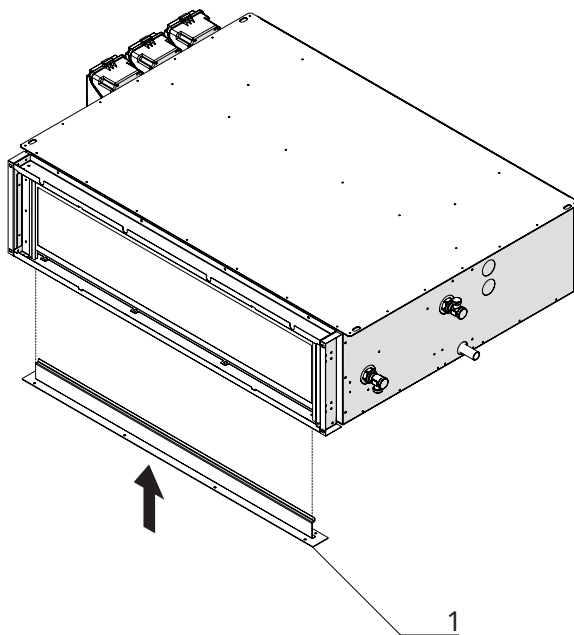
**To install the damper plate and external air intake:**

► align the damper plate and external air intake with the actuator on the same side as the electrical panel of the unit

► use the provided screws and the previously removed screws

► secure the plate onto the support frame

- 1. Electrical panel
- 2. Actuator (damper)

- 3. Damper Plate and External Air Intake

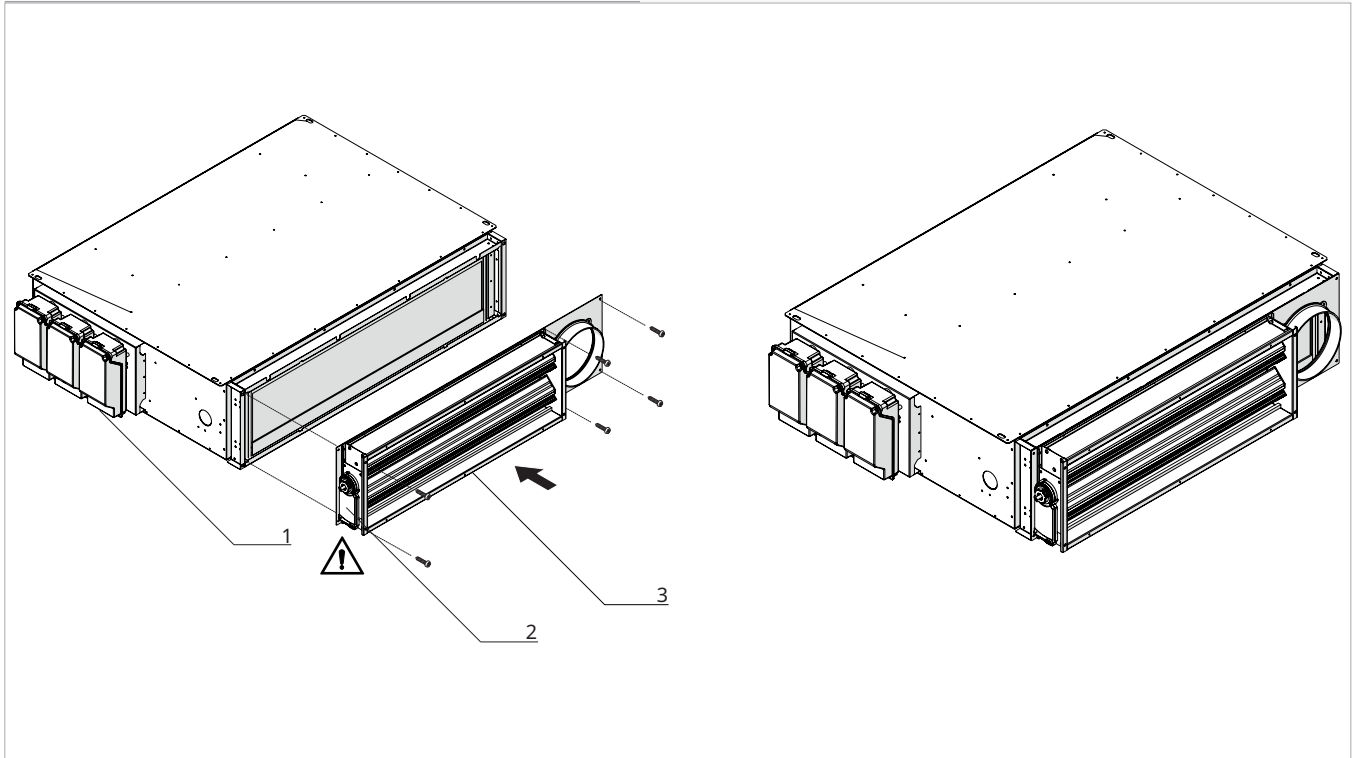

⚠ Position the damper plate with the actuator on the same side as the electrical panel of the unit.

Electrical connection

If there is a Molex connector on the unit:

► connect it to the connector provided on the external air kit

- | | |
|----|------------------|
| 1. | Electrical panel |
| 2. | Molex connector |

- | | |
|----|-------------------|
| 3. | Actuator (damper) |
|----|-------------------|

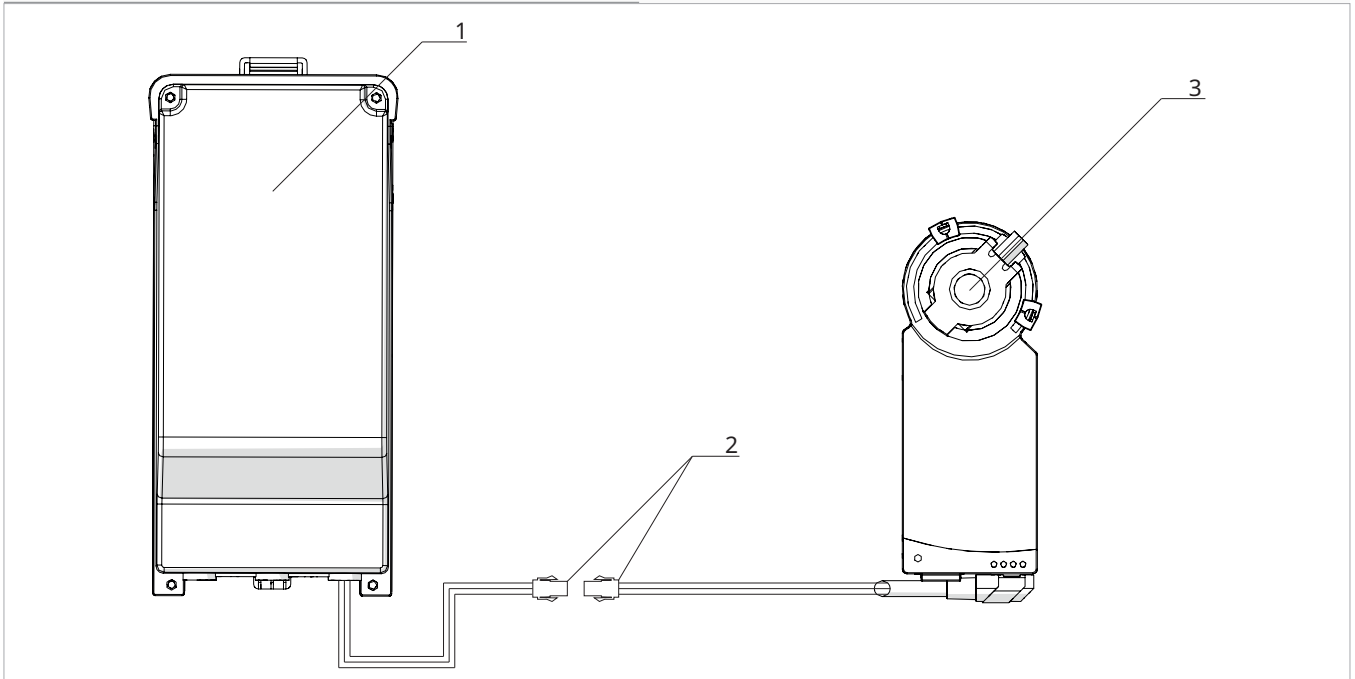

If there is a terminal block on the unit:

► remove the connector from the external air kit

► connect the cables to the terminal block

- | | |
|----|------------------|
| 1. | Electrical panel |
| 2. | Terminal block |

- | | |
|----|-------------------|
| 3. | Actuator (damper) |
|----|-------------------|

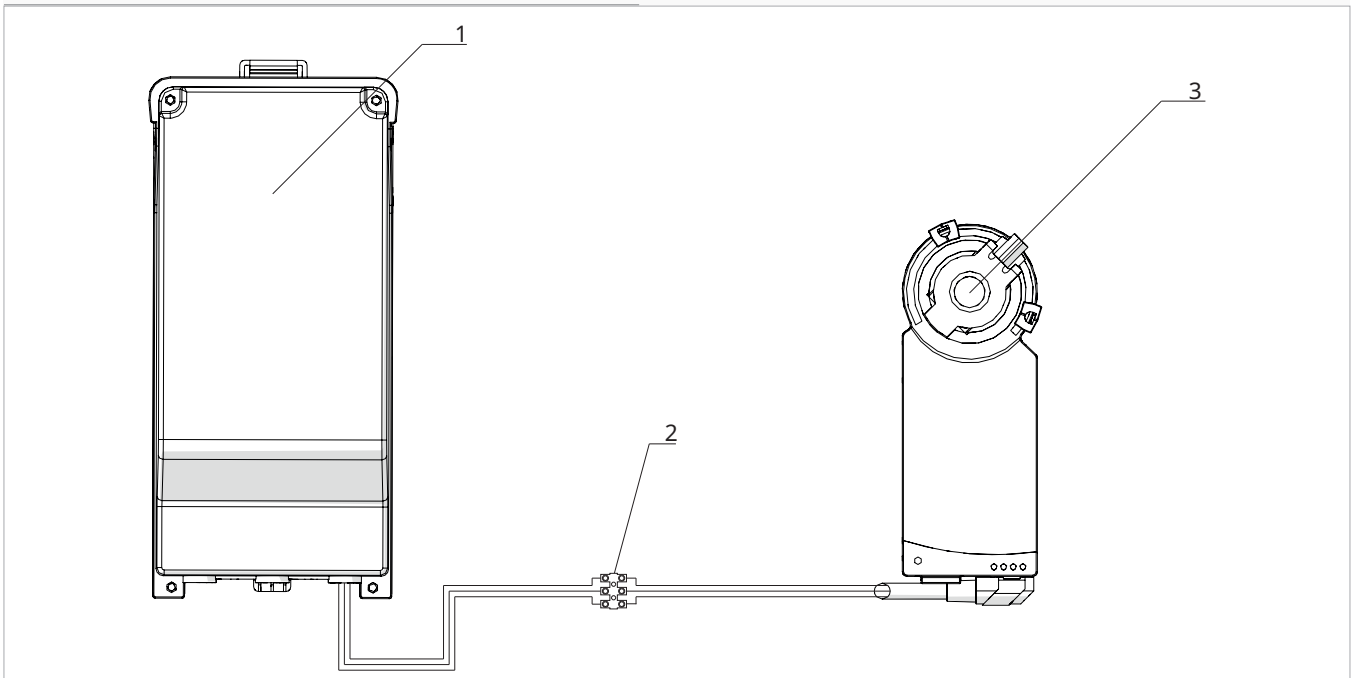

Return plenum

Installation without external air

To prepare for the accessory assembly:

- ▶ remove the filter guides from the unit by unscrewing the screws.

- ▶ remove the filter

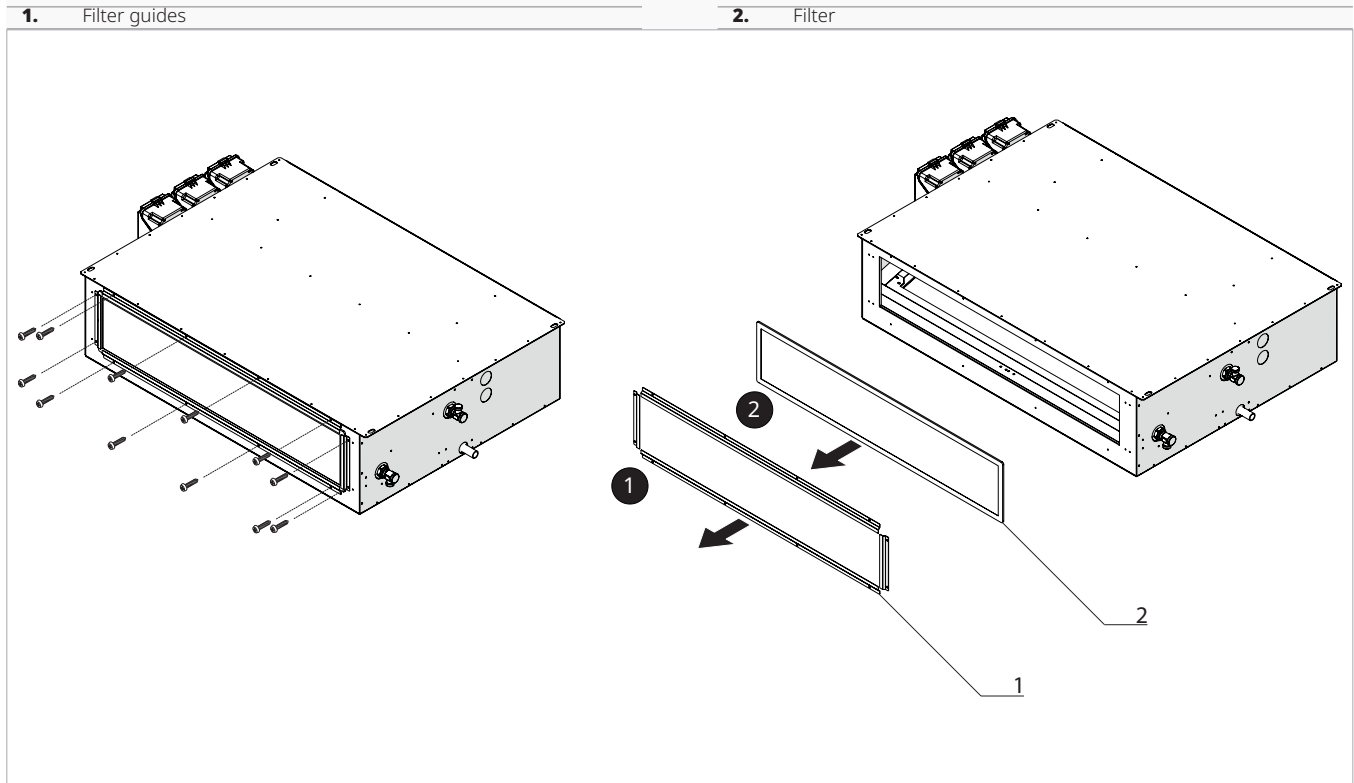

To install the support frame:

- ▶ Apply the gasket on the folds of the plenum
- ▶ Press along the entire surface to ensure uniform adhesion

- ▶ Use the previously removed screws
- ▶ secure the support frame
- ⚠ The gasket is supplied as standard

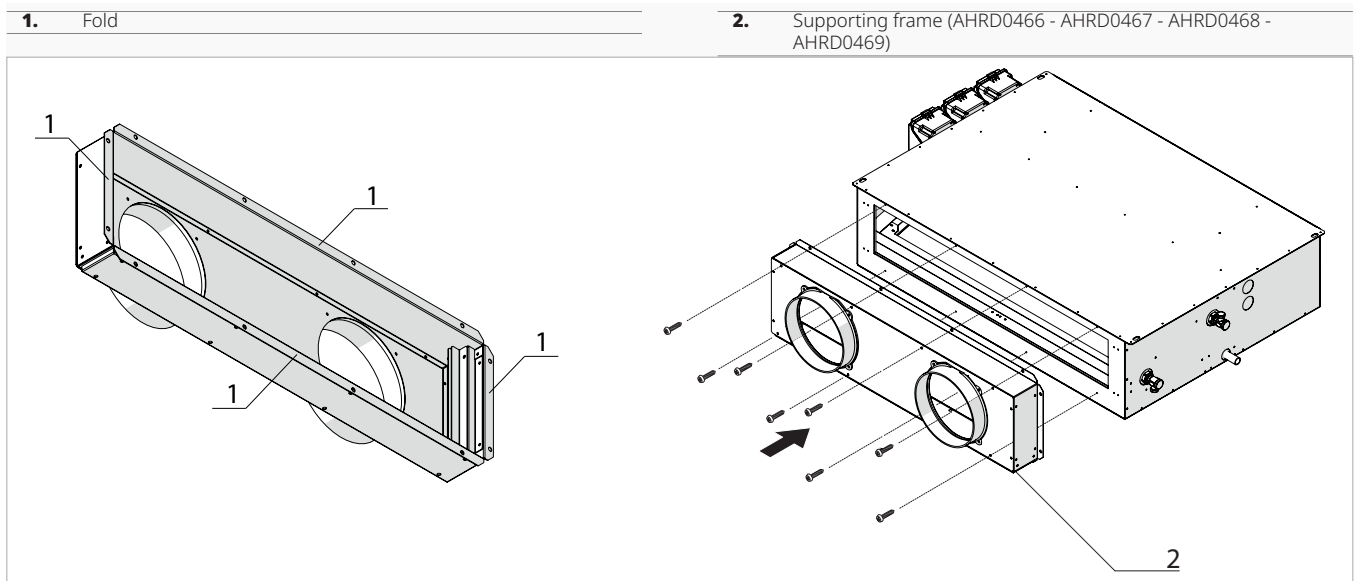

To install the filter port:

- ▶ insert the filter into the support frame guides
- ▶ use the provided screws

- ▶ secure the filter port

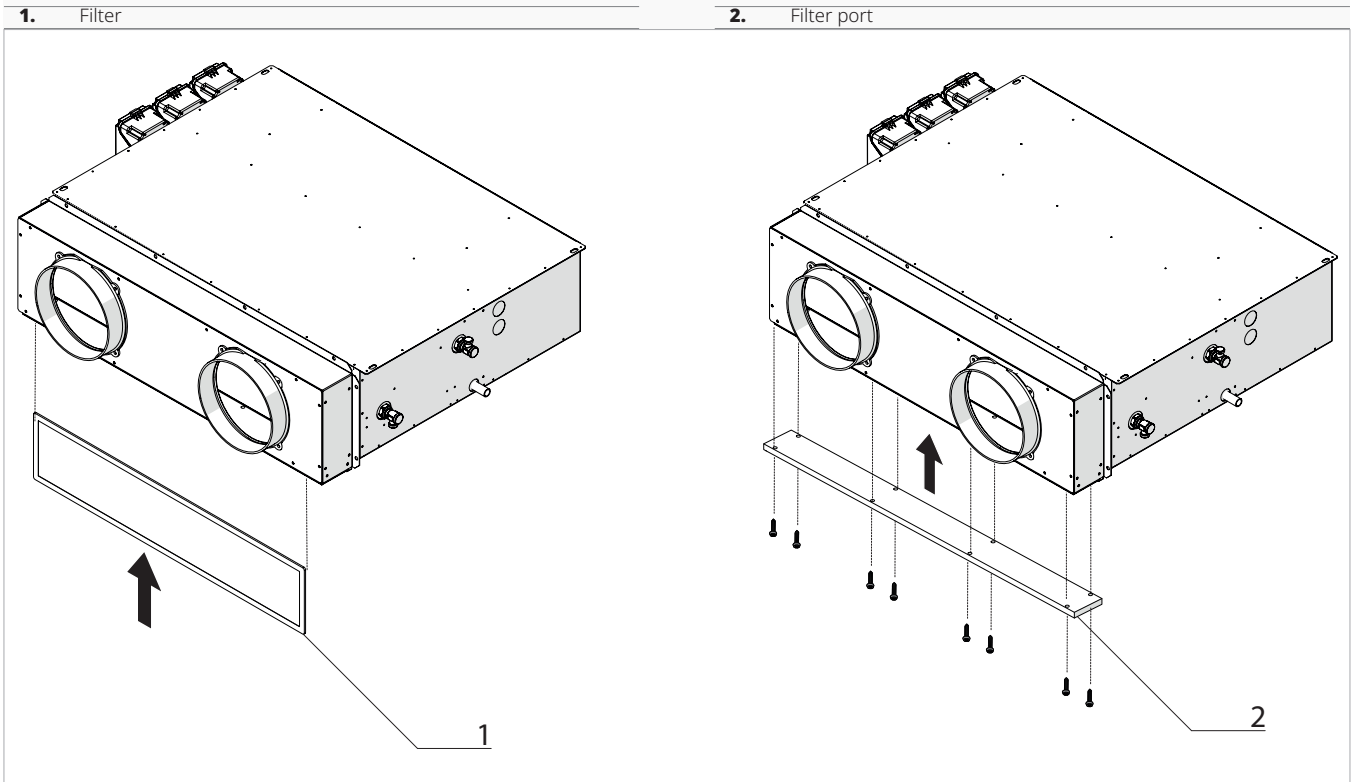

Installation with external air
To install the damper plate:

► secure the damper plate with the screws

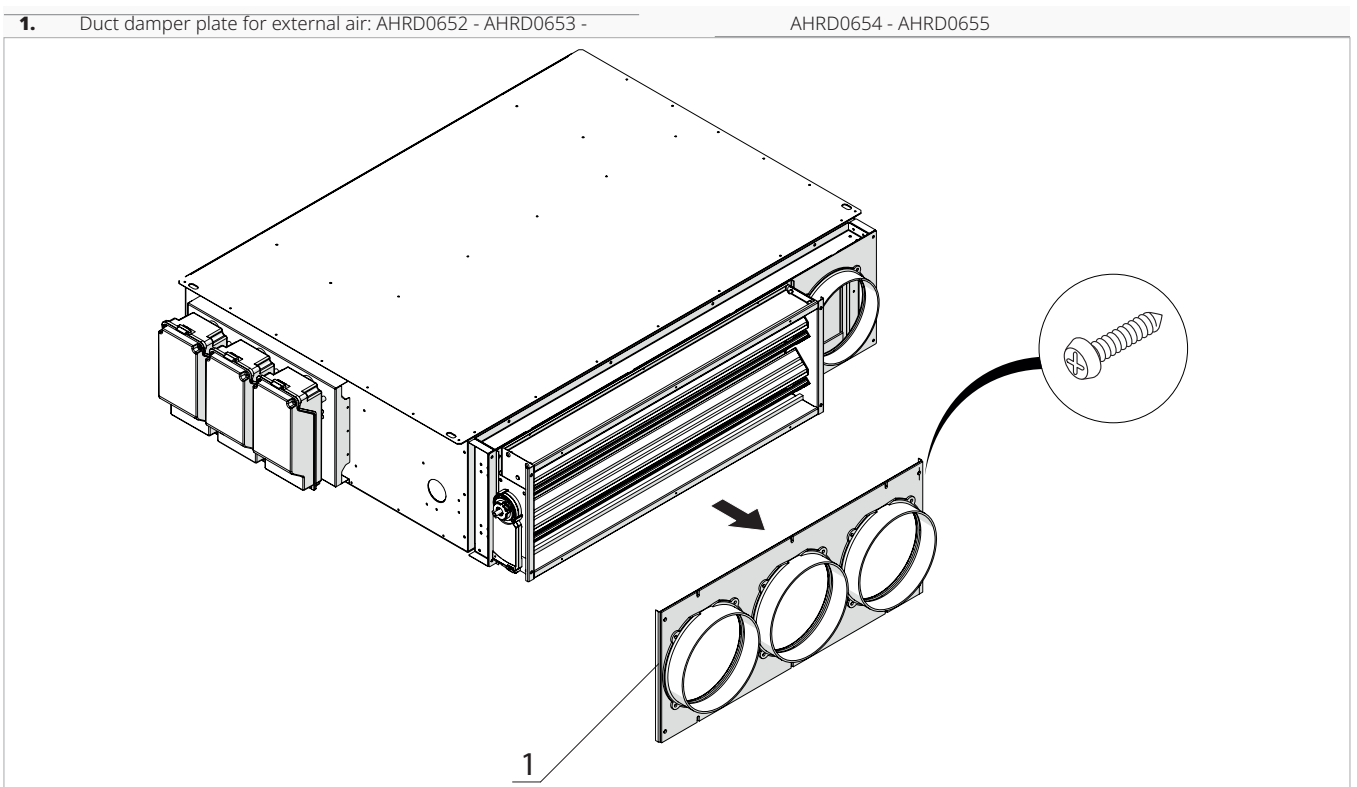

⚠ See pages 78 to 81

Plenum kit for rear intake

Installation without external air

To prepare for the accessory assembly:

- ▶ remove the filter guides from the unit by unscrewing the screws.

- ▶ remove the filter

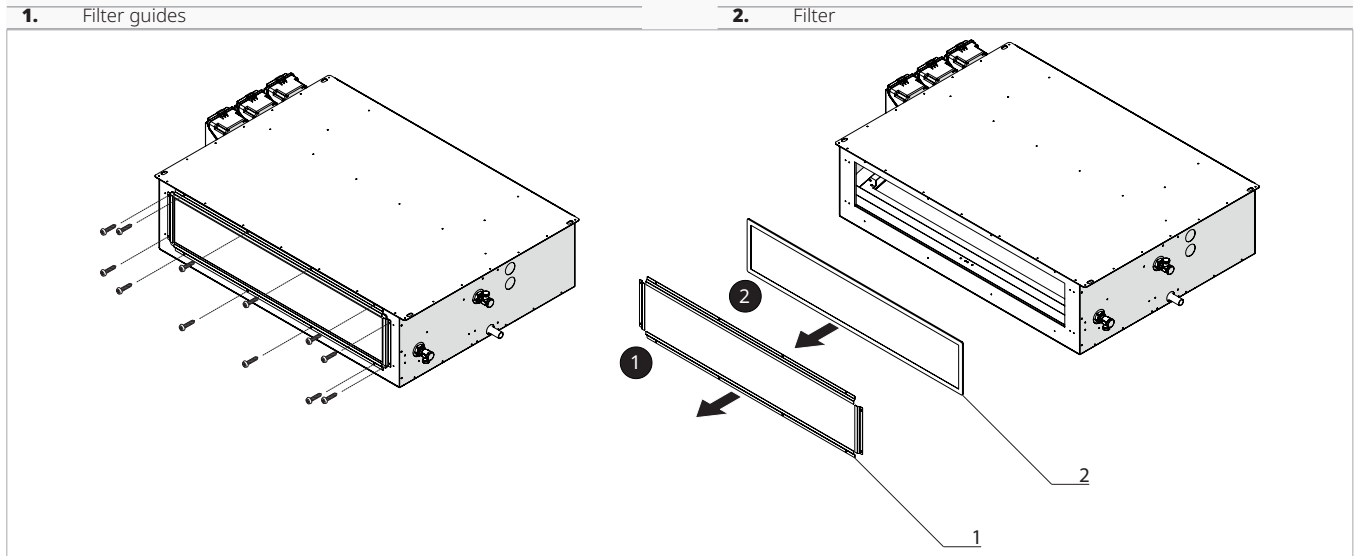

To install the support frame:

- ▶ Use the previously removed screws

- ▶ secure the support frame
- ▶ insert the filter into the support frame guides

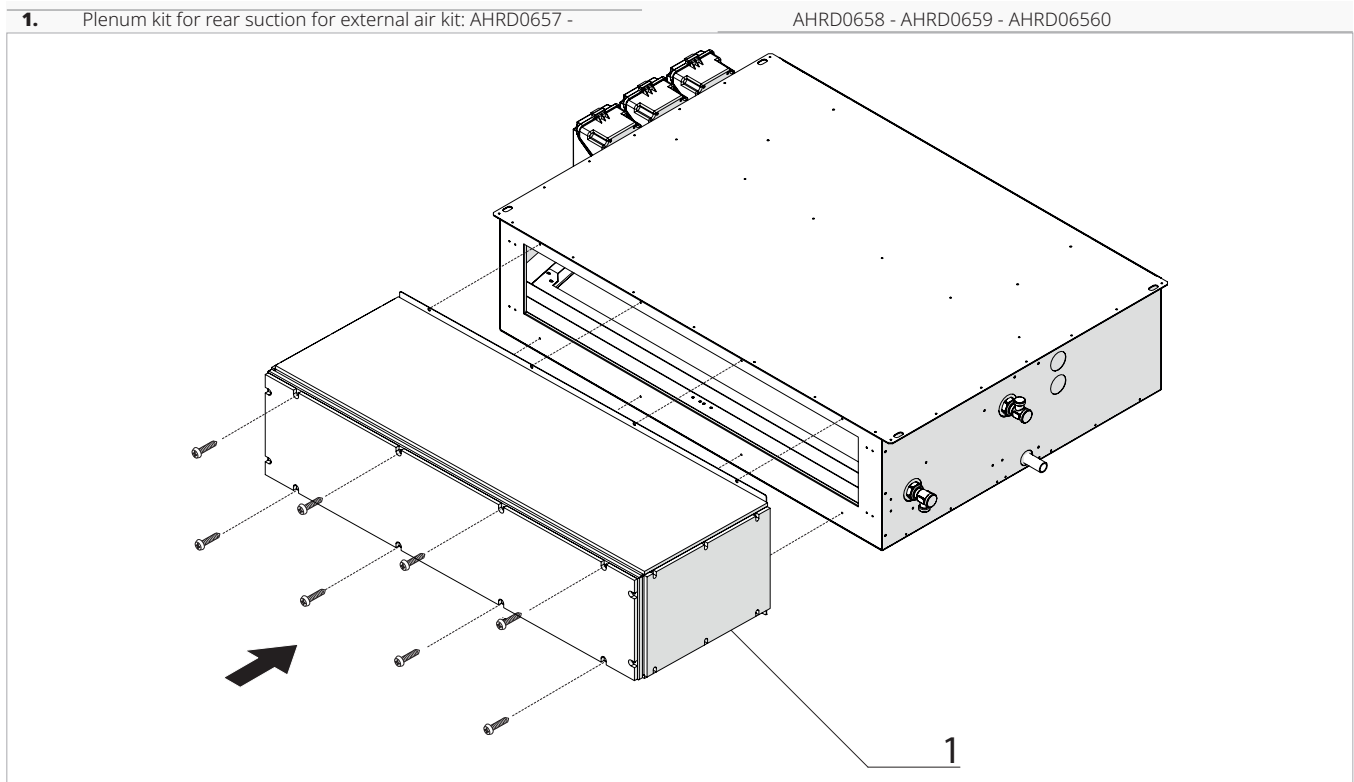

To install the telescopic kit and grille for rear suction or directly coupled:

- ▶ use the provided screws
- ▶ fix the telescopic kit
- ▶ snap-fit the grille

- ⚠ To clean and replace the filter see "Intake grille with removable aluminium filter and aluminium supply grille with double row of adjustable fins" p. 77
- ⚠ When fitting these accessories, the G2 filter and brackets must be disposed of, see points 1 and 2 on page 84

1. Plenum kit for rear suction for external air kit: AHRD0657 - AHRD0658 - AHRD0659 - AHRD06560
2. Telescopic kit for rear suction or directly coupled: AHRD0662 - AHRD0663 - AHRD0664 - AHRD0665

3. Grille for telescopic kit for rear suction. AHRD0667 - AHRD0668 - AHRD0669 - AHRD0670

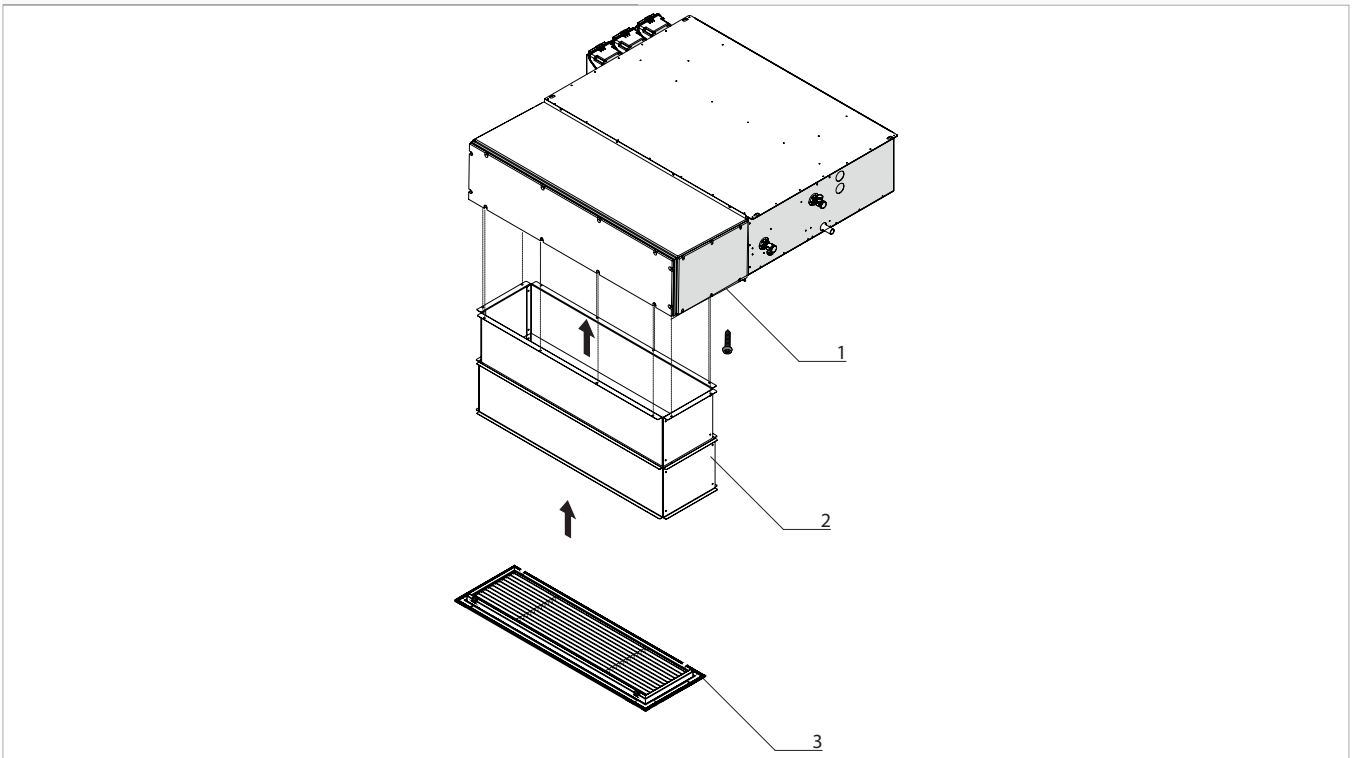

Installation with external air

To install the damper plate:

- ▶ secure the damper plate with the screws

1. Duct damper plate for external air: AHRD0652 - AHRD0653 -

AHRD0654 - AHRD0655

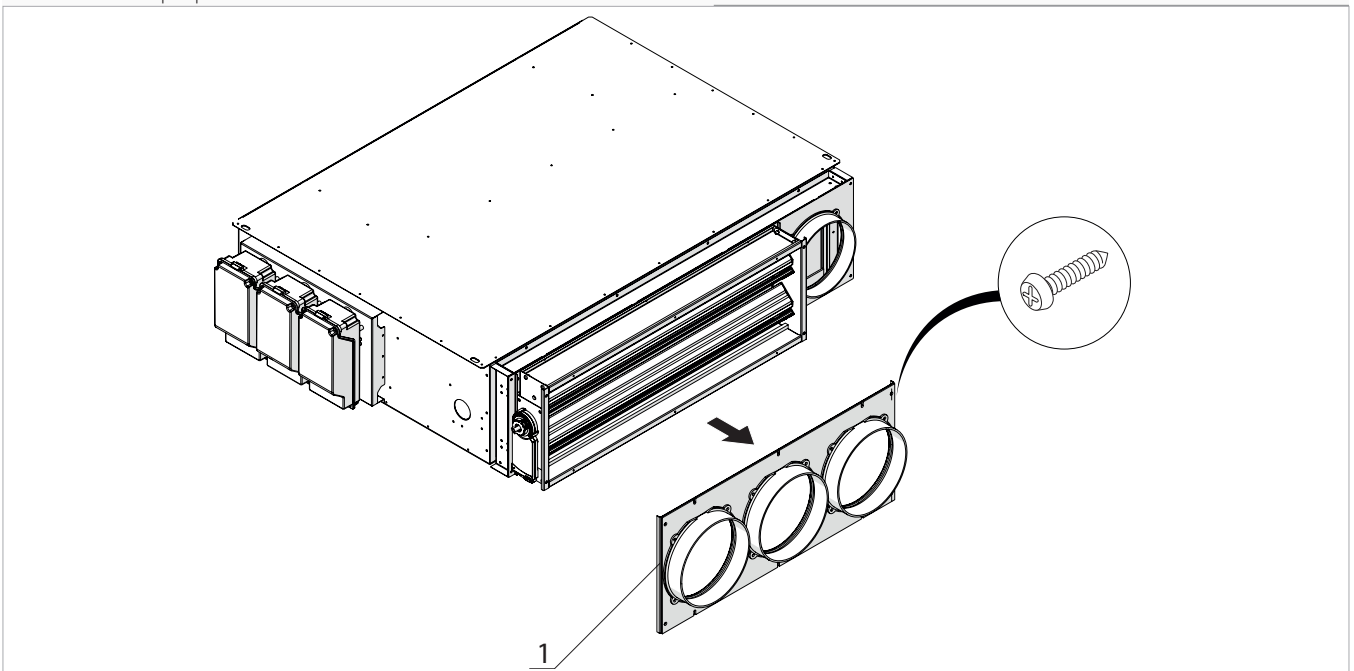

1) To install the plenum kit for rear suction:

- ▶ use the screws to secure the plenum kit

2) To install the telescopic kit for rear suction or directly coupled:

- ▶ position the telescopic kit under the plenum kit

- ▶ secure the telescopic kit to the plenum kit using the supplied screws

3) To install the grille:

- ▶ Snap-fit the grille onto the telescopic kit

⚠ To clean and replace the filter see "Intake grille with removable aluminium filter and aluminium supply grille with double row of adjustable fins" *p. 77*

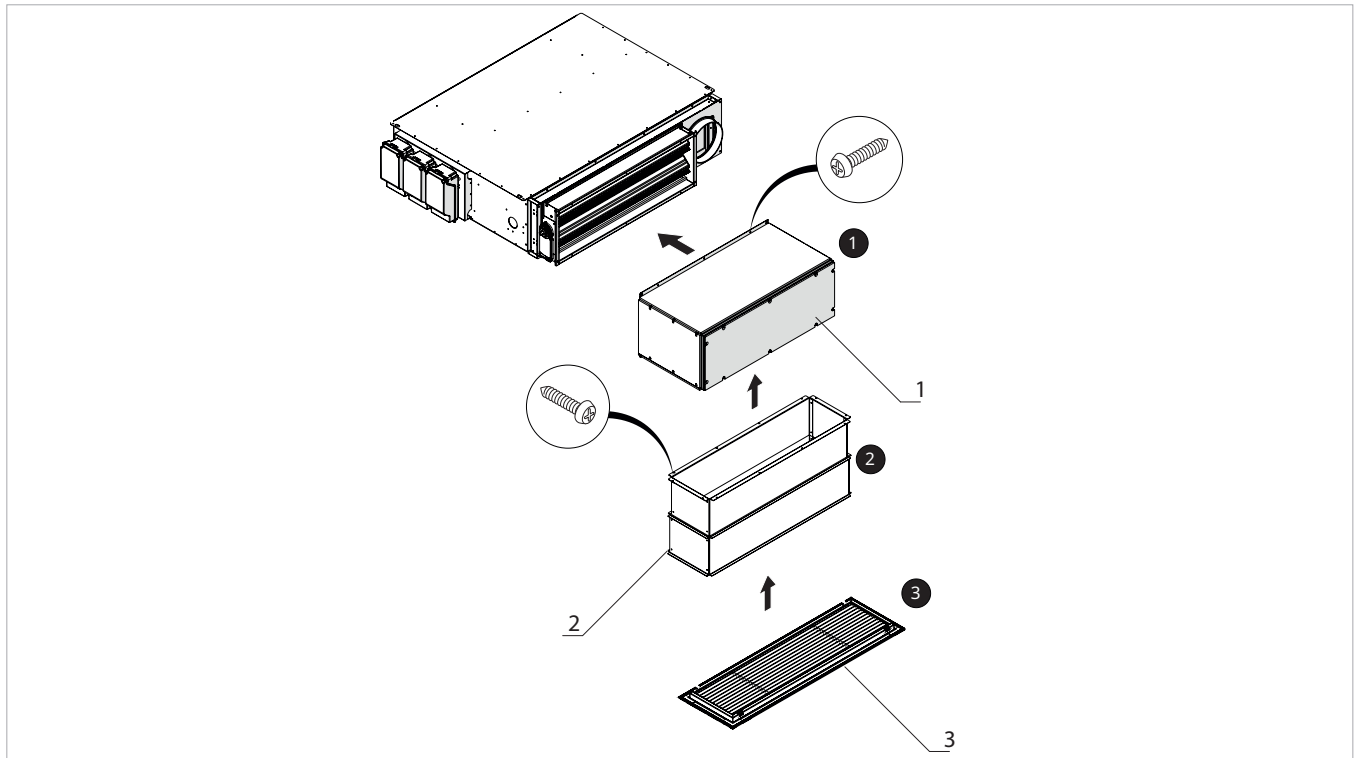

- 1. Plenum kit for rear suction for external air kit: AHRD0657 - AHRD0658 - AHRD0659 - AHRD06560
- 2. Telescopic kit for rear suction or directly coupled: AHRD0662 - AHRD0663 - AHRD0664 - AHRD0665

- 3. Grille for telescopic kit for rear suction. AHRD0667 - AHRD0668 - AHRD0669 - AHRD0670

⚠ Please refer to page 78 - 81

Panasonic[®]

Panasonic HVAC & CC Co., Ltd.
Head office: Panasonic Tokyo Shiodome
Building, 1-5-1 Higashi-Shimbashi, Minato-ku,
Tokyo
Registered office: 1006, Oaza Kadoma,
Kadoma-shi, Osaka